

SEA-1 – Triple 2A3 Amplifier

General Description

The SEA-1 amplifier is a straightforward single-ended audio power amplifier that delivers about 11 watts, using only medium and low- μ triodes. No negative feedback is used, other than local cathode degeneration. No voltage regulation or semiconductors are used in the design. The sound of the amplifier is characteristic of triodes: smooth and detailed. Despite the lack of feedback, the bass is surprisingly solid. This amplifier has been tested on a variety of speakers, and no incompatibilities have been found, except, of course, the need for relatively efficient speakers (approx. 90 db/watt or better).

The SEA-1 was designed to evaluate the prototypes of the UBT-1 transformers. In order to provide flexibility in testing, the SEA-1 was designed to be used with a separate external power supply. There is no reason why the power supply could not be included on the same chassis as the amplifier, as long as hum-inducing components, such as power transformers, are kept away from the amplifier driver circuits. The supply needs to provide 395 volts DC at 160 ma, and 6.3 volts AC at 1.8 Amps. Filtering is not critical, since filter chokes are incorporated into the amplifier. A surplus Dressen-Barnes model 30180 "Unregulated Power Supply" was used for each channel in the SEA-1 prototypes. A simple capacitor or choke-input power supply, as described in the RCA Receiving Tube Manual or Radiotron Designer's Handbook, can be used.

Note that this amplifier description is intended to aid experienced tube amplifier designers and builders. People with little experience building vacuum tube audio amplifiers should not attempt to build this amplifier based on just this

description. The voltages used in this amplifier are lethal! Precautions for working on high voltage equipment must be followed.

Measurements:

Frequency Response: 10 Hz to 44.5 KHz (-3db at 1W)

Output power and Harmonic Distortion: see graph below

Sensitivity: 22 db (to 8 ohm tap)

Damping Factor: 3.5

All measurements were made into a low-inductance 8 ohm resistor connected to the 8 ohm output tap.

Circuit Operation

Choke-capacitor filters are used for both the output and driver stages. Separating the power supply filtering this way reduces feedback from the output to the driver, and helps insure the highest possible B+ voltage to driver tube V2. Locating the filter chokes on the amplifier chassis instead of the power supply helps isolate the amplifier from external noise. Every electrolytic capacitor is paralleled with a film capacitor. R20 is a bleeder resistor to help drain the filter capacitors when powered-down.

The input stage is a conventional resistance-coupled amplifier using the octal 6J5 or 6C5. The metal version is preferred here, due to the electrical and magnetic shielding of the envelope. The cathode is only partly bypassed. The ratio of R3 and R4 was chosen to give an overall amplifier sensitivity of 22 db.

The second driver stage, using paralleled sections of a 6BL7GTA, has the difficult task of driving the highly capacitive inputs of the three 2A3's at up to 100 volts peak-to-peak. Despite the relatively low plate resistor of 12.1K, this stage is still the limiting factor in the overall high frequency response. An unbypassed cathode resistor reduces distortion in this stage, but this raises the output drive impedance, lowering the high frequency response. To compensate for this, the small capacitor C8 was added to even the response and reduce phase shift at high frequencies. C1 serves the same purpose for the first stage. This type of circuit is called "Cathode Compensation" and was developed for video amplifiers. C1 and C8 were chosen experimentally to give the flattest overall frequency and phase response.

The output stage is cathode biased, with about 20 volts extra drop in the cathode resistors to allow a bias adjustment, using R13. Medium and low frequencies are bypassed around

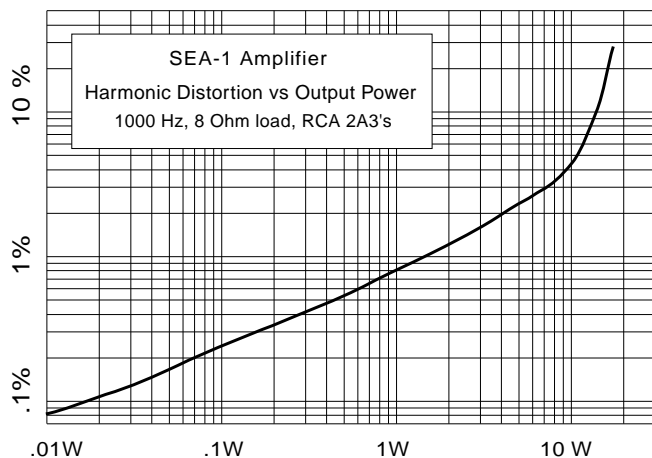

the cathode resistors R14 and R15 by the 2000 μ F capacitor, C12, at the center-tap of the 2.5V filament transformer. High frequencies are bypassed by C10 and C11 from each filament terminal to ground. This keeps high frequencies from flowing through the filament transformer and helps filter out power-line noise.

The resistors R8, R9, and R16-18 are intended to suppress parasitic oscillations. R2 helps protect the input stage from RF overloading on the input.

As with most American power transformers, the primary of T2 is rated at 115 volts, whereas the average power-line voltage in the United States is 120 volts. In order to keep the output tube filaments at the correct voltage, R19 was added in series with the primary to drop the filament voltage. Since your average power-line voltage may vary, R19 should be chosen so that 2.5 volts RMS appears on the 2A3 filaments. Similarly, resistance may be needed in the 6.3 volt filament supply. In the prototype, the wire resistance of the connecting cable supplied the correct resistance.

Variations

V1 could be replaced by a 6C4, 1/2 of a 6SN7, 1/2 of a 6FQ7, or 1/2 of a 12AU7. There is no direct replacement for V2, although two 6S4's in parallel or a 5687 should work (but these have not been tested). Replacing the 2A3's with 6A3's or 6B4G's will cause excessive hum and is not recommended unless their filaments are run from a DC supply.

Most component values are not critical. In fact, all components except the plate and cathode resistors and the compensating capacitors C1 and C8 could vary by as much as 50% without seriously affecting the amplifier's operation. The plate and cathode resistors should be chosen within 10% of the values shown. If R14 is not 160 ohms, then the bias adjustment voltage should be altered to give 140 ma through the output tubes. If a stereo pair of amplifiers is being built, component values should be matched between amplifiers to insure identical responses.

The component types specified on the schematic were chosen to give a clean sound, while still using common parts. However, experimenting with different types of components (i.e. oil-filled capacitors instead of polypropylene or bulk-foil resistors instead of metal film) is encouraged. Since there is no feedback, parts differences will be more noticeable than with feedback amps.

Output Tube Notes

Traditional American 2A3's, by RCA, Sylvania, Tung-Sol, etc. give the highest output power and lowest measured distortion. However, they are very hard to find, and are quite

expensive. The "Sino" 2A3's (made in China) are readily available at a reasonable price, but give slightly less power and higher measured distortion. In many listening tests with the SEA-1 prototypes, however, the Chinese tubes sounded better than the American tubes!

A problem has been noted with some 2A3s: occasional erratic popping, buzzing, or squealing noises. This tends to happen when they are first warming up, but sometimes persists indefinitely. These sounds are generally not microphonic, but appear to be caused by a chaotic metastable condition of the electric fields inside the tube. This seems to diminish over time, but in bad cases, the offending tube must be replaced.

Construction Notes

Construction is not critical, except to observe general good layout rules, such as keeping high signal voltage points (such as the plates of V3 through V5, and the power line), and power transformers and chokes, away from the input stage. The filament wires to V1 and V2 should be twisted and kept close to the chassis.

A variation of "star-grounding" is recommended: connect all grounds related to V1 and V2 (including C5 through C7) to one point, and all grounds related to the output stage (including C14 and C13) to another point. These two star grounds are then connected together, and tied to the chassis at a single point between the input and output.

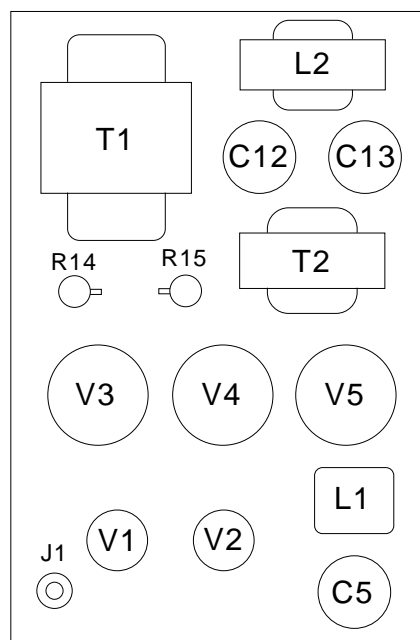

SEA-1 Chassis Layout, Top View

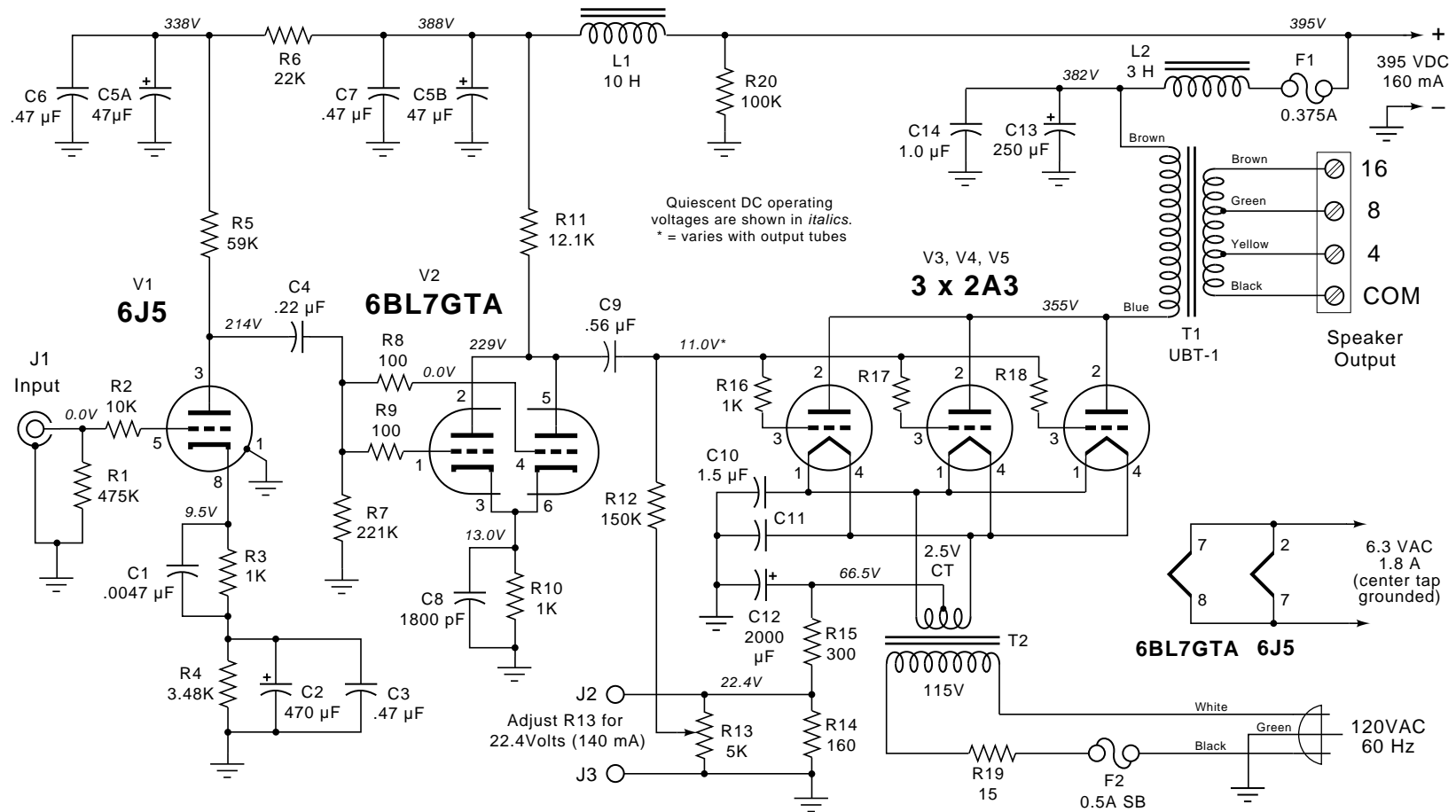

C1 – .0047 µF 100V Polypropylene
 C2 – 470 µF 25V Low-ESR Electrolytic
 C3 – 0.47 µF 100V Polypropylene
 C4 – 0.22 µF 400V Polypropylene
 C5 – 2 x 47 µF 500V Audio-grade Electrolytic
 C6, C7 – 0.47 µF 600V Polyester
 C8 – 1800 pF Glass or Mica
 C9 – 0.56 µF 400V Polypropylene
 C10, C11 – 1.5 µF 250V Polypropylene
 C12 – 2000 µF 75V Computer-grade Electrolytic

C13 – 250 µF 450V Computer-grade Electrolytic
 C14 – 1.0 µF 630V Polypropylene
 F1 – 0.375A type 3AG fuse
 F2 – 0.5A type 3AG Slow-Blow fuse
 J1 – RCA-type phono jack
 J2 – Red pin jack
 J3 – Black pin jack
 L1 – 10H, 30 mA, 515 Choke (Merit C-5503 or equivalent)
 L2 – 3H, 150 mA, 90 Choke (Stancor C-

2309 or equivalent)
 R1 – 475K 1/4W Carbon Film
 R2 – 10K 1/4W Metal Film
 R3 – 1K 1/2W Metal Film
 R4 – 3.48K 1/4W Metal Film
 R5 – 59K 1/2W Metal Film
 R6 – 22K 1W Carbon Comp.
 R7 – 221K 1/4W Metal Film
 R8, R9 – 100 1/4W Carbon Comp.
 R10 – 1K 1/2W Metal Film
 R11 – 12.1K 2W Metal Film

R12 – 150K 1/2W Metal Film
 R13 – 5K 2W Potentiometer
 R14 – 160 1% 10W Wirewound
 R15 – 300 20W Wirewound
 R16, R17, R18 – 1K 1/2W Carbon Comp.
 R19 – 15 5W Wirewound
 R20 – 100K 3W Metal Oxide
 T1 – 1600 VA, 160mA primary to 4/8/16 output transformer (One Electron UBT-1)
 T2 – 2.5VCT, 10A filament transformer (Triad/Magnatek F-3X or equivalent)

Unless otherwise noted, all resistances are in ohms.
 Star grounding is not shown.

SEA-1 – Triple-2A3 Amplifier

rev 1, 8/94, One Electron