

# WOOFER - TWEETER

**I**N some experimental work involving two speakers, a crossover network was evolved which gives very flat overall performance over a wide frequency range but which involves low-cost components. The crossover network itself follows ordinary design and may be altered to conform to derived  $m$ ,  $x$ -termination, or other configuration. The use of non-high-fidelity components to give high-fidelity performance is the point of novelty. Since many questions have been asked about the network it was felt that a description of the whole circuit, including the design steps, would be of interest.

## The Circuit

Figure 1A shows the circuit as actually set up. Each output transformer is required to work over only a narrow frequency range so that inexpensive components are used in place of high-fidelity units. Placing the network reactances in the high-impedance part of the circuit results in small capacitor values of much lower cost than the, say, 100-microfarad capacitors which would be required if placed in the 8 to 16-ohm part of the circuit.

## Design of Network

The transformer requirements are dependent upon the design of the network, so their consideration will be dealt with as part of the design.

Figure 1B shows the basis of the design, a  $\frac{1}{2}$ -section low-pass portion to allocate the low-frequency output to the appropriate load, and a  $1\frac{1}{2}$ -section high-pass portion to feed the high-frequency load. The choice of the number of sections is based on the fact that a steep cutoff for the low-pass portion is not necessary as most low-frequency loudspeakers will cut off somewhere near the crossover frequency. The high-frequency speakers, when fed power at frequencies below their

Design and construction of a crossover network for feeding a low-frequency horn and a high-frequency horn from a single amplifier, using low-cost components yet giving a response flat within 2 db from 30 to 10,000 cps, with crossover at 400 cps

By PAUL W. KLIPSCH

Hope, Arkansas

acoustic cutoff, are very apt to radiate harmonics of the received power,<sup>1</sup> and since harmonics constitute one form of distortion, this is to be avoided. Thus a steeper cutoff is provided in the high-pass filter by the choice of  $1\frac{1}{2}$  sections. Ideally, the  $\frac{1}{2}$ -section low-pass portion would produce 12 db loss per octave above cutoff, and the  $1\frac{1}{2}$ -section high-pass portion would give 30 db loss per octave below cutoff; practically, the loss is somewhat less due to the fact that the reactive elements will not exhibit zero power factor.

## Design Equations

The numerical design follows conventional practice.<sup>2</sup> The impedance level was chosen as 5000 ohms, the nominal load for a pair of type 2A3 tubes operated self bias. The class A triode was chosen because of its inherently low distortion; with pentode or beam tubes it is imperative that feedback be employed to minimize distortion within the amplifier as well as to produce a low equivalent generator impedance to prevent distortion from being produced by the speakers. The cutoff frequency  $f$  was chosen as 400 cycles. The half-section low-pass portion requires elements

$$L_k = \frac{5000}{\pi f} = 4.0 \text{ henrys}$$

$$C_k = \frac{1}{5000\pi f} = 0.16 \text{ microfarad}$$

The isolated half-section causes a nominal loss of 12 db per octave, with the intercept of the zero loss

line and the asymptote of 12 db per octave slope occurring at 1.41 times the nominal cutoff frequency. This intercept may be moved down to the cutoff frequency by doubling  $L$ ,  $C$ , or the  $LC$  product.

In a conventional half-section, the capacitance would be  $\frac{1}{2}C_k$ . This was doubled, to make  $C_1 = C_k$  so as to give 3 db loss at the nominal cutoff frequency and the desired slope beyond cutoff. Hence, in the figures  $C_1$  is twice the computed value, so that in Fig. 1B  $L_1 = \frac{1}{2}L_k = 2.0$  henrys,  $C_1 = C_k = 0.16$  microfarad, and in Fig. 1A  $L_1 = \frac{1}{2}L_k = 2.0$  henrys reckoned with the 2 windings connected series aiding and  $2C_1 = 0.32$ , two of which in series gives the equivalent  $C_1 = 0.16$ . This arbitrary change does not appear to have caused any undue variation in the input impedance.

The high-pass portion is calculated from

$$L_k = 5000/4\pi f = 1.0 \text{ henry}$$

$$C_k = 1/(5000 \times 4\pi f) = 0.040 \mu f$$

The configuration calls for architrave capacitors of  $2C_k = 0.080$  and pillar inductances of  $L_k = 1$  for the full-section and  $2C_k$  and  $2L_k$  for the following half-section. Thus  $C_2 = C_k$ . The inductance  $L_2 = L_k = 1.0$ , and  $T_2$  has a primary inductance  $L_T = 2L_2 = 2.0$ .

## Construction Details

The inductance  $L_1$  should be wound with the windings closely coupled to enforce balance; it has been found satisfactory to put one winding on top of the other. Both

# CROSSOVER NETWORK

$L_1$  and  $L_2$  should have adequate iron and copper to permit opening up a large air gap to hold the inductances reasonably constant at all levels of a-c voltage under which they will be required to operate. The matching transformer  $T_2$  can be any readily available transformer of proper ratio which will give the required 2 henrys inductance when the air gap is opened up sufficiently to hold the inductance nearly constant over all levels of excitation.

Transformer  $T_1$  should have a high primary inductance, of the order of 50 to 100 henrys to keep the exciting current low at the lowest frequencies to be transmitted, but its leakage inductance need not be held as low as demanded by expensive high-fidelity equipment; the leakage inductance as measured at the primary can be as high as one henry. Transformer  $T_2$  must have a low leakage, preferable less than 0.05 henry to hold the loss at 10 kc to less than 3 db. It may be a low-cost unit, however, since its primary inductance need be only 2 henrys after opening the air gap—say 10 henrys before adding the air gap. Transformers  $T_1$  and  $T_2$  should have the proper turns ratios to match the 5000-ohm filters to the respective loads.

Collecting and tabulating the constants for Fig. 1A gives

Impedance level.....	5000 ohms
Crossover frequency.....	400 cycles
Inductance $L_1$ .....	2.0 henrys (series aiding)
Inductance $T_1$ .....	50 henrys minimum
Inductance $L_2$ .....	1.0 henry (with air gap)
Inductance $T_2$ .....	2.0 henrys (with air gap)
Capacitance $C_1$ .....	0.16 microfarad
or $2C_1$ .....	0.32 microfarad
Capacitance $C_2$ .....	0.04 microfarad
or $4C_2$ .....	0.16 microfarad
Leakage ind. of $T_1$ .....	not over 1.0 henry
Leakage ind. of $T_2$ .....	not over 0.05 henry

Conversion of the constants given for other impedance levels and/or other crossover frequencies is well known and will not be discussed.

The fact that a pair of 2A3 or 6A5G tubes exhibits a plate imped-

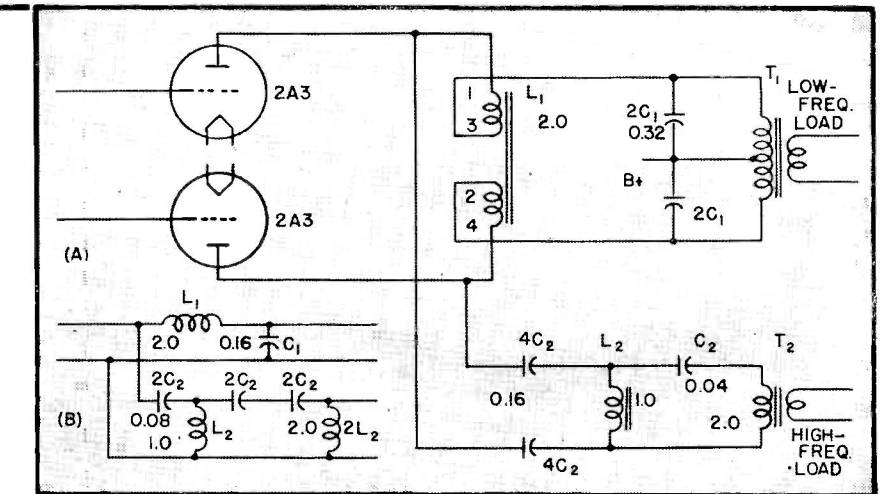

FIG. 1—Actual circuit of crossover network (A), and elementary circuit (B) used for design purposes

ance of only 2000 ohms when the load impedance and the surge impedance of the filters are 5000 ohms raises the question of reflections. The mismatch is not great enough to cause serious reflection from a theoretical standpoint. A measured performance curve shows each output to be flat in its transmission range and to fall off smoothly in its attenuation range. The mismatch is necessary for proper loading of the output tubes and if this is a necessary evil from the filter standpoint it is of sufficient unimportance in the present application to be disregarded. It should be remembered that speaker voice-coil impedance is itself highly variable.

## Performance

This crossover network has been in experimental use with a speaker combination comprising a low-frequency horn<sup>3</sup> operating between 40 and 400 cycles and a high-frequency horn operating from 400 cycles up. Two types of low-frequency horns and three types of high-frequency horns, all of different acoustic length, have been tried in various combinations. The output appears smooth throughout the transmission range including that in the immediate vicinity of crossover. Phase relations at this point seem to have little or no bearing on performance. Even complete 180-

degree reversal of one speaker (in any of the several combinations) makes no difference in performance. Thus phase shifts in the described crossover network or in the speakers themselves may be neglected. Of course, if two identical speakers are used on one channel, they should be properly phased to prevent peculiar radiation patterns.

An obvious advantage of this crossover network is the fact that low-cost components may be used to give the same high-fidelity performance as more expensive equipment. The experimental model was constructed at less cost than that of a single high-fidelity matching transformer, and the performance is such that the combined power output is flat within 2 db from less than 30 cycles to over 10,000 cycles.

The design presented here may be considered the result of developing a pilot model. It is felt that the arrangement will be found advantageous for quantity production in connection with multiple speakers applied to home radios or for more specialized uses.

## REFERENCES

- (1) Klipsch, P. W., A Note on Acoustic Horns, *Proc. I.R.E.*, 33, No. 7, p. 447-449, July 1945.
- (2) Terman, F. E., "Radio Engineers' Handbook," McGraw-Hill Book Company, New York, 1943, p. 228-229.
- (3) Klipsch, P. W., A Low Frequency Horn of Small Dimensions, *Jour. Acous. Soc. Am.*, 13, No. 2, p. 137-144, Oct. 1941. Improved Low Frequency Horn, *Jour. Acous. Soc. Am.*, 14, No. 3, p. 179-182, Jan. 1943.