

An A. C. Phonograph Amplifier ★

Constructional Details of a High-Quality Unit Operating from House Current

By JAMES MILLEN

THE phonograph and the radio set are companion entertainers, and each renders a particular service which cannot be performed by the other. Audio amplifiers and sound reproducers of similar design may be used by both; and, with the new electrically-made records, the modern phonograph provides high-quality reproduction, like the best radio receivers.

This article describes the construction of a high-quality A.F. amplifier, suited for use with either a radio set or a phonograph; it is A.C.-operated and provides ample volume for all requirements, with practically undistorted rendition. Properly installed, it will modernize old-type radio sets and phonographs.

—EDITOR.

EVEN with the present high development of radio broadcasting, and the excellent diversified programs always available, there are bound to be times when one would prefer a program of his own arrangement; perhaps just a few favorite selections. Or again, if there is an electrical storm or if reception for some one reason or other is not up to standard, then a whole evening's entertainment may be desired. But who, after becoming accustomed to the well-nigh perfect—as far as the ear can tell—fidelity of reproduction of which the modern radio is capable, is content with an old-time phonograph?

But while radio has been making rapid strides toward that much-sought goal—"perfect tone quality"—phonograph and acoustical engineers have not been asleep. They have, themselves, investigated the new fields of electrical magnification and reproduction of sound opened up for them by radio invention. They have taken the best of radio amplifiers and speakers, and developed "pick-ups", needle-scratch filters and other necessary paraphernalia for converting the minute vibrations, which the phonograph record imparts to the needle, into pulsating electrical currents, which can be fed into the audio end of a conventional radio set.

Radio's contribution to the phonograph

industry did not, however, end with the development of an entirely new system of sound reproduction.

BETTER RECORDING METHODS

In former times, the recording artist, or group of artists, while making a phonograph record, had to huddle in a congested, uncomfortable and unnatural fashion before a large horn into which they played or sang; those in front, singing or playing unnaturally low, and those behind them unnaturally loud, in an attempt to produce an even balance of volume on the finished record. Large bands, choral groups and symphony orchestras were of necessity greatly curtailed in order to get within an effective range of the recording "funnel."

Now, however, one can scarcely distinguish between a phonographic recording salon and a radio broadcast studio. There is no funnel; no crowding; no unnaturalness on the part of the artists. Instead, they perform in their most natural way, while the microphones are placed to pick up each voice or instrument in its proper relation to the others.

In fact, the output of the electric phonograph, when one gets right down to the matter, is but a standard broadcast program which, instead of being sent over the air, is recorded and delivered to the consumer without picking up static or other disturbances en route.

The acoustical difference between the same piece, played by the same orchestra over a high-grade broadcast station on a quiet night and played on an electric phonograph is nil; assuming, of course, that the audio-frequency amplifier and loud speaker used in both instances are of similar quality.

EACH TO ITS PLACE

With these improvements, and one other—the elimination of the record scratch—the



The electrified phonograph in its cabinet. The output may be connected to either the balsa-wood speaker on the wall or the cone in the cabinet.

modern phonograph becomes a highly desirable companion to the modern radio receiver. Static and SOS signals no longer need spoil an evening's entertainment. Favorite selections, beautifully rendered and reproduced, are available at a moment's notice, when the radio program is not tempting.

But do not understand this article to be an argument in favor of the phonograph over the radio. The phonograph can never take the place of the radio. First, the radio brings into the home news and entertainment as it actually occurs: banquets, speeches, sporting events and many others; and secondly, radio supplies its own program. Its repertoire is not limited by the number of records in the album. But, as a companion to modern radio, there is a distinct service to be performed by the electrically-operated phonograph.

Let us divide the electrical phonograph

T1 and T2, power transformers; CK1, choke; R6, potentiometer; R7, R8, R9 and R12, fixed resistors; C4 and C5, filter condensers.

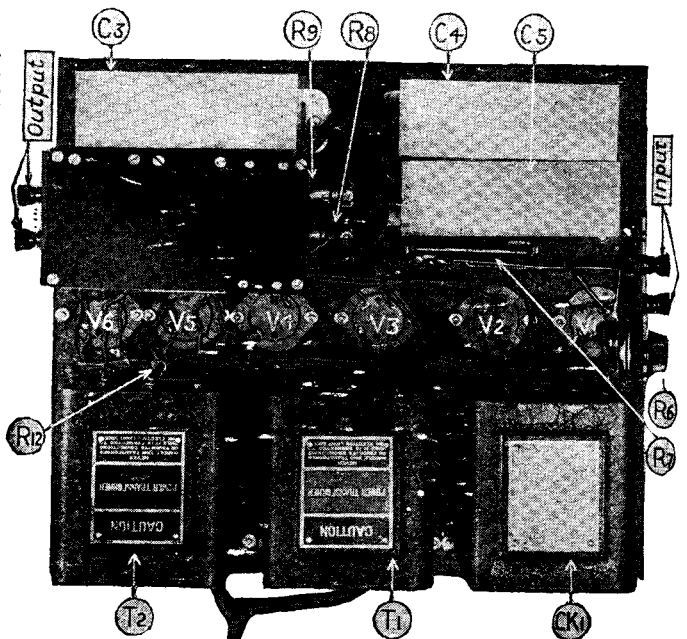
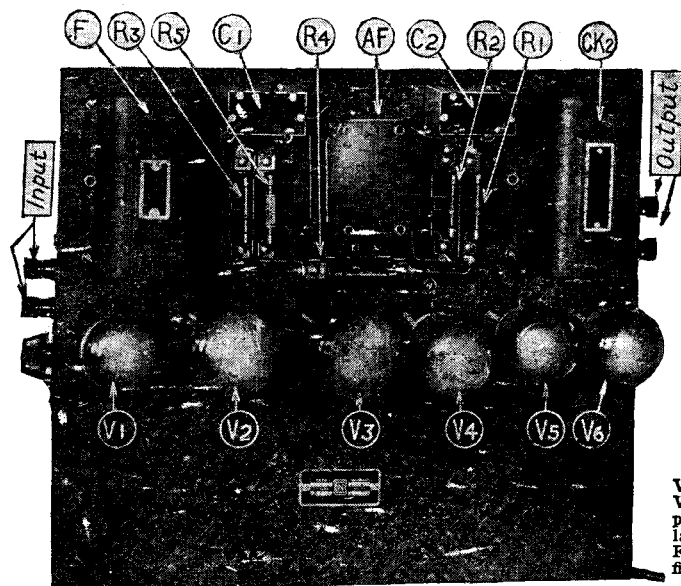

V1, A.F. amplifier; V2 and V3, power amplifiers in push-pull; V4, voltage-regulator; V5 and V6, rectifiers; F, scratch-filter; R1 to R5, fixed resistors; and CK2, plate-output impedance.

into its several component parts and consider each by itself.

THE PICK-UP

The pick-up is the device which converts the mechanical vibrations, imparted by the record to the needle, into electrical vibrations. There are at least four different types of pick-ups.

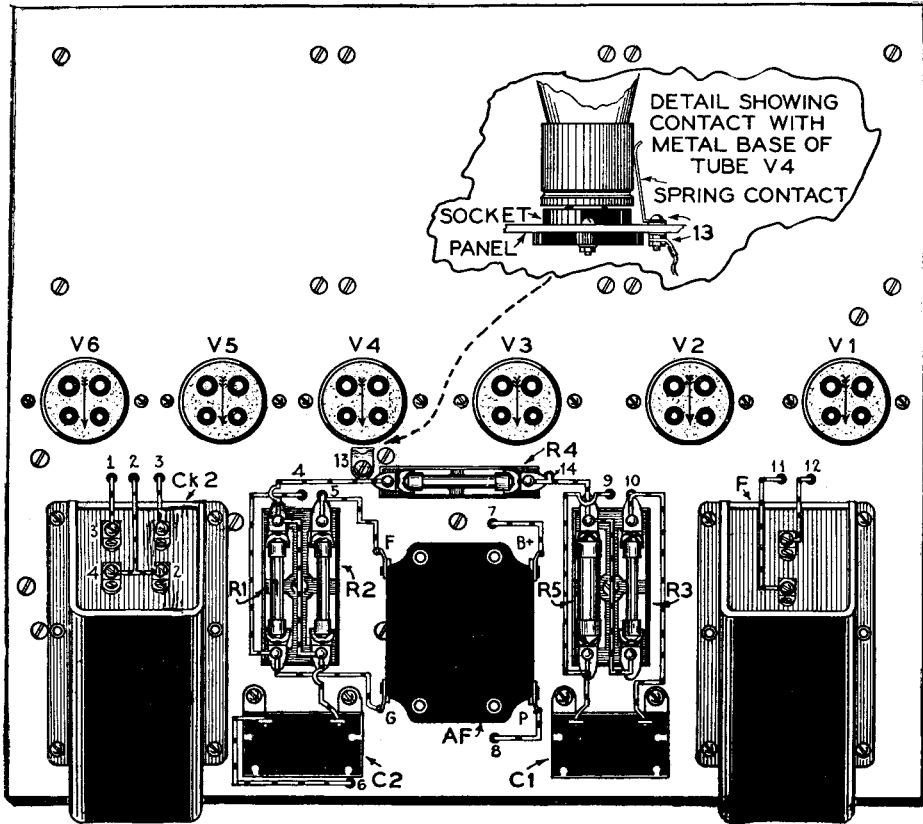

The wiring diagram of the A.C. Phonograph Amplifier, showing the leads connecting the instruments located on the top of the panel. Note detail of connection to base of the voltage-regulator tube.

The electromagnetic and piezo-electric or crystal types function by generating electrical currents of their own; while the capacity and the carbon-grain forms operate by variation in the impedance of a circuit in which they are placed. All of these four different

types have at one time or other made their appearance in commercial form.

The present crystal types, while capable of excellent quality, are expensive and fragile. Those of the carbon type, when constructed to give really good quality, are also

expensive; and, in addition they require a small storage battery or several dry cells for their operation. Even so, no commercial models which have yet made their appearance can equal, in tone quality, the performance of some of the better electromagnetic devices.

Of the capacity type, much has been said in recent issues of RADIO NEWS. Such a pick-up is capable of very excellent tone quality and is less expensive than a really good electromagnetic type, but has the rather serious disadvantage of requiring a pair of separate vacuum-tube oscillators, with their attendant "A", "B" and "C" supplies.

There are, however, available on the market at the present time, at quite reasonable prices, several very excellent pick-ups of the electromagnetic variety. This pick-up consists, essentially, of a permanent magnet of the horseshoe type, between the poles of which are located the pair of double pole-pieces, the balanced armature and the armature coil. Movement of the armature, at one extremity of which is located the needle, results in a variation in the flux passing through the armature, and thus linking with the turns of fine wire on the coil. This variation in flux, in turn, induces a varying or alternating voltage in the coil.

VOLUME CONTROL

As the output of the pick-up is alternating current, any device which will provide a ready method of controlling the magnitude of this voltage without in any way distorting its wave form, or altering the load impedance into which the pick-up works, will prove satisfactory. Fortunately, a simple, inexpensive device which meets these requirements is the high-resistance type of potentiometer used in many radio sets. Fig. 2 shows how the potentiometer is connected in the circuit. Most commercial pick-ups are supplied complete, including a volume-control potentiometer having the proper load impedance for the pick-up with which it is to be used.

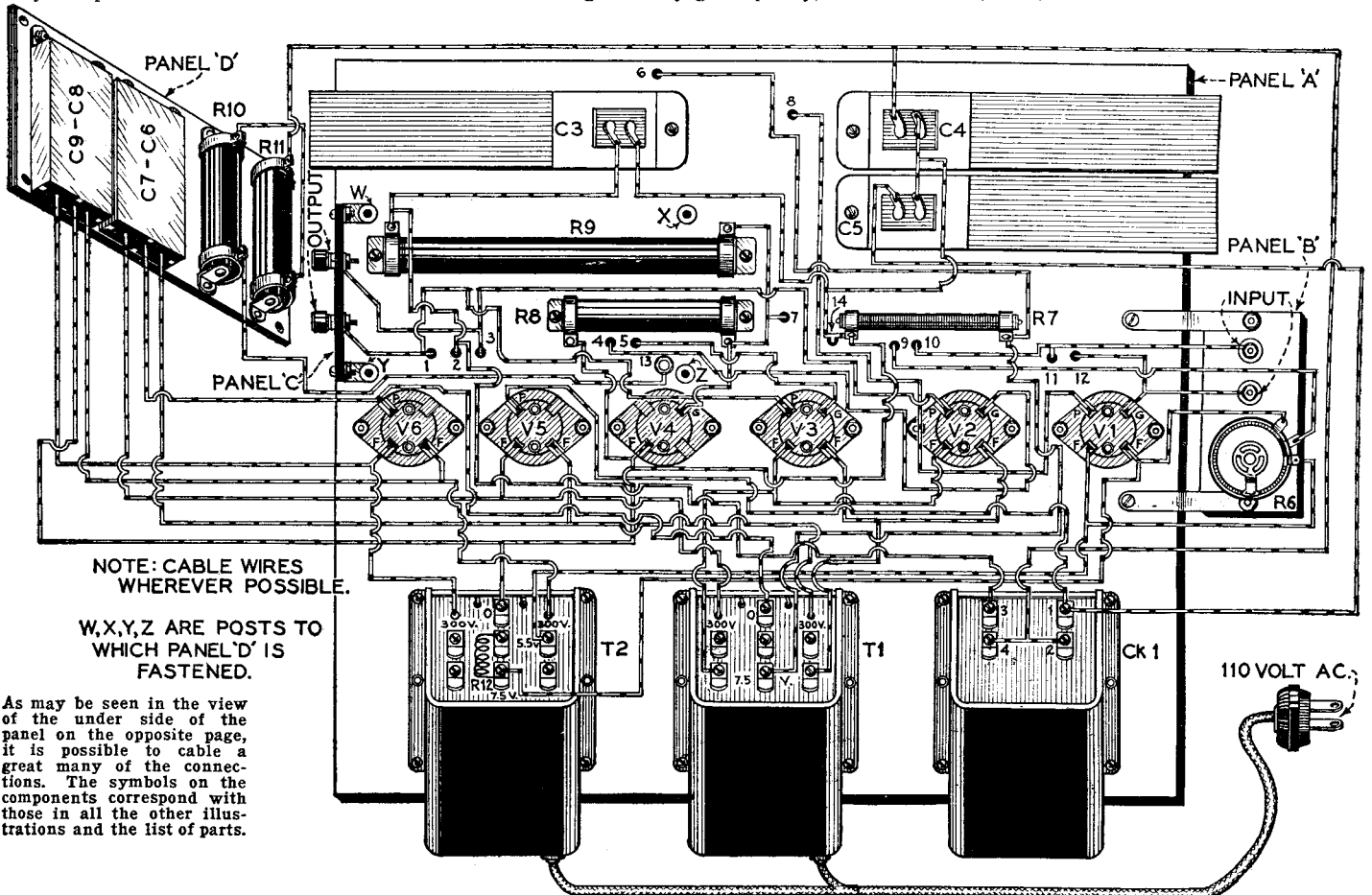

NOTE: CABLE WIRES WHEREVER POSSIBLE.

W, X, Y, Z ARE POSTS TO WHICH PANEL 'D' IS FASTENED.

As may be seen in the view of the under side of the panel on the opposite page, it is possible to cable a great many of the connections. The symbols on the components correspond with those in all the other illustrations and the list of parts.

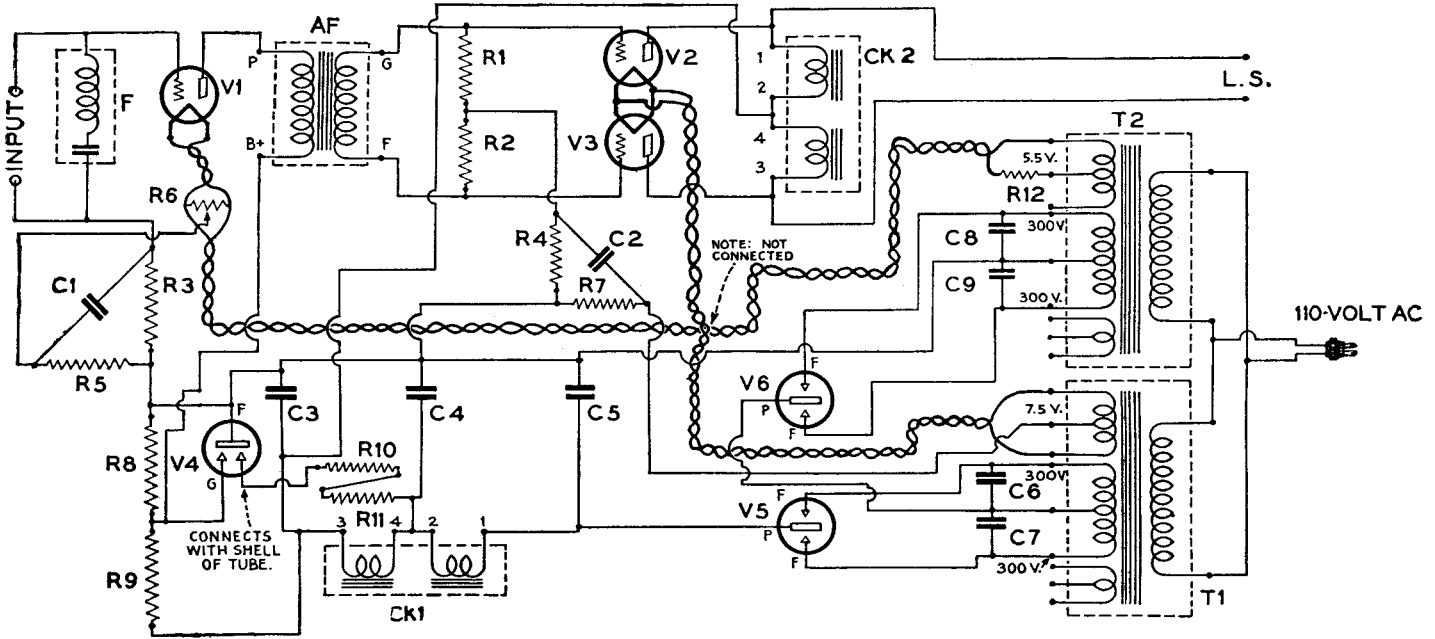

The schematic diagram of the Phonograph Amplifier, which, as may be seen, is entirely operated from the A.C. power mains.

THE SCRATCH FILTER

Aside from tone quality, one of the outstanding achievements in the new phonographs is the elimination of surface noises and needle "scratch." The use of a new material for the manufacture of records has done much to mitigate this annoyance of the past; but its final and complete elimination is accomplished by means of an electrical filter circuit, so tuned as to suppress scratch frequency. Such an electrical filter is connected between the pick-up and the amplifier. The filter is so located before, rather than after the amplifier, in order to prevent unnecessary overloading of the latter.

While the connection of a .006-mf. fixed condenser across the output of the pick-up (or input to the amplifier) will remove this noise, such an arrangement will at the same

time remove many of the higher audio frequencies and thus lower the quality of reproduction. For this reason an electrical filter tuned to stop the passage of only those currents in the neighborhood of the scratch frequencies is used.

The difficulty in completely eliminating the scratch lies in the fact that it is not of any one frequency, but covers quite a wide band. If, however, the filter circuit is tuned to approximately 4500 cycles, the greater part of the scratch noise is removed without sacrifice of tone quality. The residual hiss is practically unnoticeable when a scratch filter is employed, and cannot be detected except for the first few seconds or so before the music starts.

Such a device may either be purchased as a complete unit or may be home-constructed

from a choke coil and condenser, so selected as to be most effective at about 4500 cycles. This frequency peak should be somewhat "broadened" by the use of a very small quantity of iron in the construction of the inductance unit.

While an electrical filter circuit of the type indicated in the diagram will remove objectionable scratch from the music issuing from the loud speaker, it will not prevent one from hearing the unamplified scratch noise directly from the record. For this reason the lid of the turntable compartment should be kept closed while records are playing.

THE AMPLIFIER

Amplifiers of many different types are suited for electrical phonograph use; the audio end of almost any high grade radio set is capable of quite excellent results. The author has, however, designed primarily for phonograph use the amplifier hereinafter described, and has incorporated in the design several features which particularly fit it for such use.

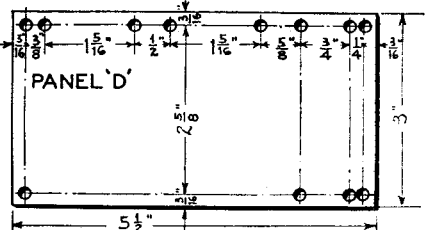
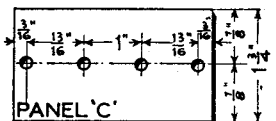
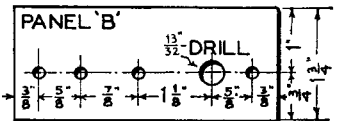
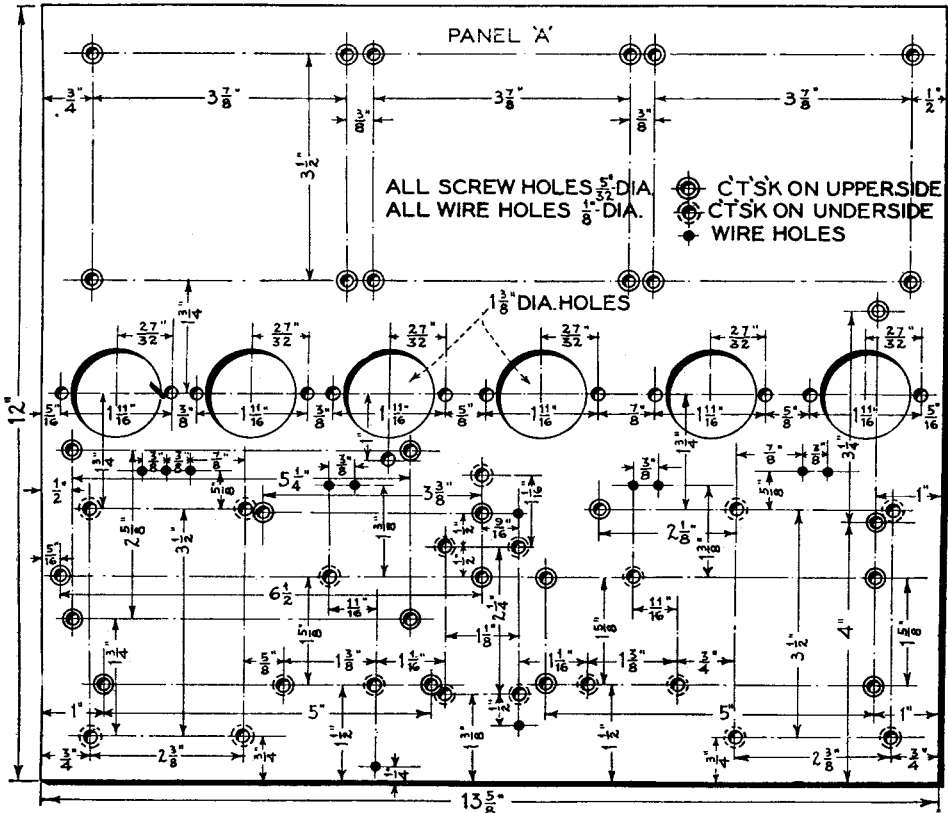

NOTE: ALL SCREW HOLES 5/32" DIA. How the four panels are drilled for mounting the various apparatus and the locations of the holes through which the connecting leads are run, is shown in the above drawings.

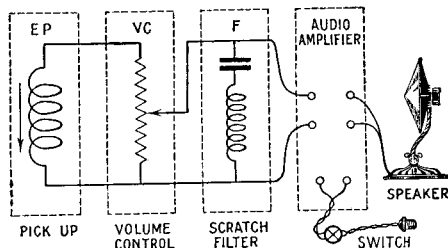

Fig. 2
This diagram illustrates the electrical circuit of the pick-up, the volume control and scratch filter.

First, it is all A.C. operated, no batteries of any kind being necessary. Second, by the use of two of the 210-type power-amplifier tubes in a push-pull amplification circuit, an unusually high undistorted watt-output is obtainable. This is essential for natural reproduction of the lower tones and musical notes at full volume. Furthermore, the use of a push-pull circuit reduces to an entirely negligible value the slight A.C. hum that would otherwise result from the heating of the power-tube filament by means of raw alternating current.

A standard high-quality audio transformer (AF) has been adapted to the push-pull circuit by the use of two 500,000-ohm resistors (R1 and R2) across the transformer secondary to establish the electrical equivalent of a center-tap.

In the input stage is employed an A.C. tube (V1), which overcomes much of the trouble experienced with former amplifiers employing the fragile and highly-microphonic 199-type tube for such a purpose. Current for the filament of this tube is obtained from the five-volt secondary winding of transformer T1, and a short length of resistance wire (R12), removed from an old rheostat, is connected in the circuit to reduce the voltage. The correct amount of wire needed for this purpose is determined by experiment.

The power supply section of the amplifier also boasts of several innovations. One is the use of two full-wave 300-volt gaseous-conduction rectifier tubes (V5 and V6) connected with their outputs in series; the necessary 600 volts is thus supplied by the full-wave filamentless rectification method, with but two inexpensive and long-lived tubes. Another innovation is the use of the 3-element voltage regulator (V4), described by the author in detail in the October issue of RADIO NEWS. Aside from stabilizing the operation of the amplifier and maintaining the "B" and "C" voltages at their proper values regardless of line-voltage fluctuations, the regulator tube also contributes largely to the lack of hum and to the good tone quality, due largely to its action as the equivalent of a 50 to 60 microfarad condenser across the high voltage plate supply.

FEATURES OF THE DESIGN

The somewhat unusual layout and assembly employed in the amplifier are also the result of an attempt to improve its performance and otherwise better adapt it for phonograph use.

First of all, the power supply is located below the heavy steel base plate (panel A); while the audio channel is located above, in order to reduce the amount of stray magnetic flux from the power transformer and first filter choke, which might otherwise be picked up by the audio transformer or the grid circuits of the amplifier tubes.

Secondly, all unprotected high-voltage leads are below the base plate. In fact, everything has been removed from in front of the row of tubes in order to facilitate their replacement, when necessary, without any attendant danger of shock.

Incidentally, placing the hot tubes above and the filter condensers, with their impregnation of low-melting-point paraffin, below, overcomes one of the most troublesome and

common faults of a great many amplifiers in which the rectifier or power tubes are placed quite close to the filter condensers. This results in an exceedingly short life for, not only the condensers, but generally much other apparatus in addition. A shorted filter-condenser will in many cases wreck the power transformer and rectifier tube at the same time.

Still another rather important point that has been given due consideration is physical size. The amplifier is sufficiently compact to fit readily into the average phonograph console in place of the old horn below the motor, avoiding the sacrifice of record storage space to house the electrical equipment.

THE LOUD SPEAKER

As the final component in the line-up of apparatus employed for the electrical reproduction of phonograph records, we have the loud speaker.

Anyone of several of the better types of loud speakers now available may be employed with most satisfactory results, where the device is not to be built directly into the cabinet. In the case of the console illustrated, two distinct types of built-in loud speakers are employed, with suitable switches for using either or both, as desired. One consists of a baffle-board type of electro-dynamic cone, with its field coil connected in series with the second filter inductor of the amplifier's power supply. This baffle and cone are mounted in the opening in the front of the console, which results when the

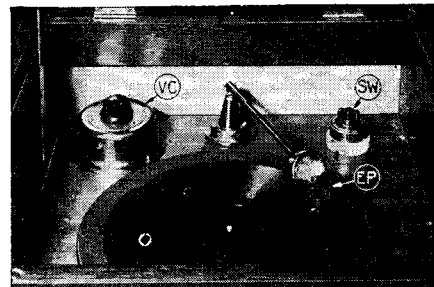

VC is the volume control, EP, the pick-up, and SW, the switch, which are placed in the turn-table compartment.

old wooden horn is removed to provide space for the amplifier. The rear of this compartment should be provided with a rather large opening, in order to prevent excessive "air clamping" of the cone. The baffle is a piece of 1/2 inch white pine, fastened in place with glue and long, thin wood screws.

The other speaker is of the balsa-wood type, shown from one of the kits now available on the market, hanging from the wall, where it presents a decorative effect, similar to a picture. The frame of an undecorated speaker of similar type may be readily suspended from and parallel to the bottom of the cabinet, thus being hidden from view.

After the above changes have been made, we will have an instrument truly modern as far as performance is concerned; the only (Continued on page 830)

SYMBOL	Quantity	NAME OF PART	REMARKS	MANUFACTURER ★
T1, T2	2	Power transformers	300-volt secondary with center tap	1 11, 12, 13, 14, 15, 16, 17, 32
Ck 1	1	Filter choke	Two coils in one unit	1 11, 12, 13, 14, 15, 16, 17, 32
Ck 2	1	Plate choke	Two coils in one unit	1 11, 16
F	1	Scratch filter		1
AF	1	Audio transformer	Second stage type	2 11, 12, 13, 14, 15, 16, 17, 18, 34
C1, C2	2	Filter condensers	1 mf., 450-volt rating	3 5, 17, 19, 20, 21, 22, 23
C3	1	Filter condenser	4 mf., 1,000-volt rating	3 5, 19, 20, 21, 22, 23
C4, C5	2	Filter condensers	2 mf., 1,000-volt rating	3 5, 19, 20, 21, 22, 23
C6, C9	2	Buffer cond. units	Two .1 mf. condensers in each unit	3 5, 17, 19, 20, 21, 22, 23, 34
R1, R2	2	Fixed resistors	.5 megohm, grid-leak type	4 3, 17, 22, 23, 24, 25, 26, 36
R3, R4	2	Fixed resistors	.1 megohm, grid-leak type	4 3, 17, 22, 23, 24, 25, 26, 36
R5	1	Fixed resistor	1,000 ohms, cartridge type	4 3, 5, 17, 22, 23, 24, 25, 26, 36
R6	1	Potentiometer	30 ohms	5 14, 22, 32, 35
R7	1	Fixed resistor	750 ohms, wire wound, 10 watts	4 5, 22, 23, 24, 25, 26, 28
R8	1	Fixed resistor	10,000 ohms, 20 watts, wire wound	4 5, 17, 22, 23, 24, 25, 26, 28, 34
R9	1	Fixed resistor	12,000 ohms, 20 watts, wire wound	4 5, 22, 23, 24, 25, 26, 28
R10, R11	2	Fixed resistors	40,000 ohms, 20 watts, wire wound	4 5, 22, 23, 24, 25, 26, 28
V1	1	Amplifier tube	226 type	6 25, 29, 30
V2, V3	2	Power tubes	210 type	6 25, 29, 30
V4	1	Voltage regulator	Three-element type	7
V5, V6	2	Rectifier tubes	Full-wave gaseous type	7 6, 31
	6	Tube sockets	UX type	8 12, 14, 17, 26, 32, 33, 34, 35, 37, 45
	4	Binding posts		8 26, 32, 34, 38
	2	Resistor mounts	Double	4 17, 22, 23, 24, 25, 26, 28, 34
	1	Resistor mount	Single	4 17, 22, 23, 24, 25, 26, 28, 34
		Hook-up wire	Insulated	10 20, 40
EP	1	Phonograph pick-up	Magnetic type	9 25, 32, 39, 41
R12		Resistor wire	(See text for description)	
VC	1	Volume control	Potentiometer type	9 39, 41
SW	1	Switch	Standard 110-volt snap switch	
A	1	Steel chassis	13 7/8 x 12 x 1/8 inches	
B	1	Panel	1 1/2 x 4 inches	42 43, 44
C	1	Panel	1 1/2 x 3 inches	42 43, 44
D	1	Panel	3 x 5 1/2 inches	42 43, 44
WXYZ	4	Brass posts	2 7/8 x 1/2 inch tubing	

NUMBERS IN LAST COLUMN REFER TO CODE NUMBERS BELOW.

1 National Company, Inc.	2 American Transformer Company	3 Toke Deutchmann Company
4 Arthur H. Lynch, Inc.	5 Carter Radio Company	6 C. E. Mfg. Company (CoCo)
7 Raytheon Manufacturing Company	8 H. H. Eby Mfg. Company	9 American Bosch Magneto Corp.
10 Cornish Wire Company	11 Sanson Electric Company	12 Silver-Marshall, Inc.
13 Dongan Electric Mfg. Company	14 General Radio Company	15 Jefferson Electric Mfg. Co.
16 Thorderson Electric Mfg. Co.	17 Leslie F. Ruter Company	16 Ferranti, Inc.
19 Dubilier Condenser Corporation	20 Acme Wire Company	21 Potter Manufacturing Co.
22 Polymet Manufacturing Company	23 Aerovox Wireless Corporation	24 International Res. Co. (Durham)
25 Davon Radio Corporation	26 Amaco Products, Inc.	27 Ward-Leonard Elec. Co.
28 Electrad, Inc.	29 Radio Corporation of America	30 E. T. Cunningham, Inc.
31 Q.R.S. Music Company	32 Electrical Research Lab. (ERLA)	33 De Jur Products Company
34 Pilot Electric Mfg. Company	35 Herbert H. Prost, Inc.	36 Allen-Bredley Company
37 Benjamin Elec. Mfg. Co.	38 XL Radio Laboratories	39 Patent Electric Company
40 Belden Manufacturing Company	41 Brooklyn Metal Stamping Co.	42 Micarta Fabricators
43 American Hard Rubber Company	44 Formica Insulation Company	45 Air Gap Products, Inc.
46	47	48

★ THE FIGURES IN THE FIRST COLUMN OF MANUFACTURERS INDICATE THE MAKERS OF THE PARTS USED IN THE ORIGINAL EQUIPMENT DESCRIBED HERE.

If you use alternate parts instead of those listed in the first column of manufacturers, be careful to allow for any possible difference in size from those originally used in laying out and drilling the panel and sub-base.

From copyright, 1927, E. C. Pub. Co.

A Phonograph Amplifier

(Continued from page 779)

"antique" device in the system is the spring motor of the phonograph. Though the preferred arrangement, for an A.C. operated phonograph, includes the use of an induction motor to operate the turntable, such motors of the proper size are rather difficult to obtain. Most phonograph dealers, however, stock excellent motors of the universal type, which, as they are run only when the radio receiver is not in operation and will therefore cause no interference, are entirely satisfactory. Such motors cost from \$15.00 to \$30.00, depending upon the type. Generally an allowance is made for the old spring motor if it is turned in at the same time.

If the spring motor is retained in the phonograph, then the amplifier should be so placed that the rectifier and power tubes, which become quite warm in operation, are at one side and not directly under the motor; for such placement might result in the melting of the graphite in which the spring is packed.

If the spring motor is replaced by an electric drive, then, of course, no thought need be given to the location of the amplifier.

CONSTRUCTING THE AMPLIFIER

If the builder will carefully study the several accompanying pictures, diagrams and drawings of the complete amplifier little difficulty should be encountered in its construction.

The soft-steel base plate may be either prepared at home or constructed by a local machine shop. The name "steel" seems to scare many home constructors who think nothing of drilling their own bakelite and even brass panels. They have a surprise in store for them when they find out just how easy it is to drill, file, and saw a piece of soft steel.

The plate may be finished with enamel, crystal lacquer, or just polished and varnished. It should be given some kind of protective finish, however, to prevent it from rusting. After the finish has dried, the different holes should be retapped, so that the mounting screws will automatically ground the cases of the various component parts.

The wiring should be neatly done with a flexible tinned wire having a high-voltage insulation. When the wiring has been completed, it should be bound together with a waxed thread into cable form. Extreme care should be used, when passing wires through holes in the base plate.

THE GROUND CONNECTION

A ground connection to the negative side of the filter circuit is highly desirable. In most instances this may be obtained through a 2-mf. condenser to one side of the 110-volt line. The 110-volt line connections may have to be reversed to see which way is best. This is readily accomplished by merely plugging into the lamp socket, or base outlet, first one way and then the other.

It is also desirable in some instances to ground the case and supporting arm of the pick-up; also to try reversing the leads from the pick-up to the amplifier.