

Effect of the Cathode Capacitor on P-P Output Stage

ROBERT M. MITCHELL

Because of the fact that some amplifiers use a bypass capacitor across the cathode resistor in the push-pull output stage and some do not, the conclusions reached in this paper should be of considerable interest. Note, however, that these conclusions refer only to Class A amplifiers, while most modern amplifiers are designed to work up into the Class AB region.

WITH THE CONTINUED INTEREST in audio circuitry and design, it has become worthwhile for the audio engineer to re-examine some of the procedures that formerly were taken largely for granted. Among these procedures is the use of the by-pass capacitor in a Class A push-pull output stage. The purpose of this capacitor seems evident enough, yet the engineer is constantly finding circuits without this component and just as frequently finding circuits with it. To make the matter more puzzling still, he will read one author's admonition that its use is absolutely necessary, and another's that its use is specifically to be avoided.

In view of this ambiguity of opinion, it was felt that a test of the differences would be interesting. The results, which are not always as anticipated, are presented in this article, along with some evaluation of the outcome. The nature of this investigation necessitated the examination of some of the effects of balancing techniques in the output stage as well, and the results of this phase of the undertaking are also presented here.¹

The Problem

Proponents of bypassed cathode operation maintain, among other things, that since the even-order harmonic terms which are generated in the output stage of necessity pass through the common cathode resistor, they therefore appear between grid and cathode of both tubes, are thus introduced as signal, and appear in the output. While it is quite true that these even harmonic terms do appear as a voltage drop from each grid to the

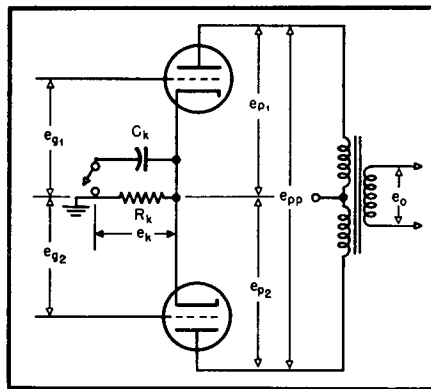

Fig. 1. Basic push-pull output stage arranged to switch capacitor in or out of circuit for measurements described.

common cathode, it is also true that since they appear as in-phase inputs at each grid, they are cancelled in the push-pull stage.

Another and more serious charge is that the even-order distortion terms of all kinds which pass through the cathode resistor may cross modulate with the input voltage and thus introduce additional intermodulation distortion terms which, not necessarily being in phase with each other, may appear in the output.

As a representative of the other ("unbypassed") school of thought, Williamson states: (*Wireless World*, May 1947) "A feature of this arrangement is that the valves operate with a common unbypassed cathode bias resistor, which assists in preserving the balance of the stage under dynamic conditions," and in the August 1949 issue: "Due to the use of common unbypassed resistors for the push-pull stages, the amplifier is largely self-balancing to signal. . ."

Here, then, are the two opposing views on the subject, and the reasons advanced for each by their respective proponents. Although the reasons advanced seem to be different, it is reasonable to assume that reduction of distortion is also the effect desired by Williamson, since this

is one of the results of a balanced stage.

The Initial Approach

Figure 1 shows the basic push-pull output circuit with signal voltages labeled and the bypass capacitor in question, C_k , shown in series with a switch which will allow it to be inserted or removed at will during the course of measurements. It should be noted that this is the common type of push pull circuit, and the entire discussion which follows is confined to this circuit and does not necessarily apply to the "single-ended" or "series d.c." type of push-pull circuit.

The actual amplifiers used in the test were the UTC W-10 Williamson amplifiers, since these conform almost exactly to Williamson's circuit. (See Fig. 2.)

First Tests

The first measurements made were of total harmonic distortion, using a General Radio Type 1932-A Noise and Distortion Meter, and a low-distortion oscillator. The input frequency was 50 cps and measurements were made at power levels from 4 watts up to overload. These initial tests were made on an amplifier using 5881's in the output stage, and gave very consistent results. The addition of the bypass capacitor always increased the distortion, regardless of power level. The increase was very slight, but nevertheless very definite. The total distortion was small, so it became very difficult to measure, especially since the distortion of the oscillator itself was of the same order of magnitude as that of the amplifier. Consequently, it was decided to measure the performance without feedback. This change would increase the distortion, of course, but would not affect the action of the capacitor. The results of this test were similar, with distortion increasing when the capacitor was used. (See Fig. 3.) These results were obtained consistently after numerous checks and rechecks, in-

¹ The measurements described here were made at the laboratories of the United Transformer Company during the period when the author was director of those laboratories.

cluding tests at higher frequencies (500 and 2000 cps). Several curves were drawn and the data was about to be assembled for write-up when it was decided to substitute some other type of output tubes and see if there was any difference. Accordingly, a pair of 1614's was substituted and the tests re-run. The results were as complete a reversal of the trend as could be imagined! Almost every test showed lower distortion with the capacitor in the circuit. A typical measurement is illustrated in Fig. 4. In view of such conflicting results, it was decided to re-measure with as many different tube types and amplifiers as possible. Consequently, the test schedule outlined below was evolved.

(1) Four different stock amplifiers with 1614 tubes were checked for total harmonic distortion on a distortion meter.

(2) The same four were checked for individual harmonic distortion components on a wave analyzer.

(3) The measurements of (2) were made with different degrees of current unbalance.

(4) One amplifier was checked with four different sets of output tubes, all of which are directly interchangeable in the UTC W-10. These four sets included two pairs of 1614's and one each of KT66's and 5881's.

(5) The amplifier of (4) was checked for intermodulation distortion with the three tube types mentioned above.

(6) The amplifier of (4) was examined for transient distortion by the square wave method, with differing degrees of current unbalance.

(7) All measurements were made with the 100- μ f bypass capacitor

switched in and out of the circuit and the comparisons made point-by-point on an A-B basis. Care was taken to prevent any transient disturbance during connection or disconnection of the capacitor from being included in recorded data.

Results

The outcome of the harmonic distortion measurements of (1) was very inconclusive at low frequencies. The addition of the capacitor either reduced or increased the distortion depending on which type of tube was used, and even varied among tubes of the same type. At the higher frequencies, however, the addition of the capacitor quite consistently increased the distortion.

This ambiguity of results pointed up the need for a more refined analysis, so the next step was to measure the individual harmonic components on a wave analyzer. A fundamental frequency of 50 cps was chosen, and the second and third harmonics were checked, with output tube currents adjusted to produce these four different conditions:

- (1) Minimum unbalanced current
- (2) Minimum 3rd harmonic in the output
- (3) Maximum unbalanced current in one direction
- (4) Maximum unbalanced current in opposite direction

Again the results were indefinite, with different tube types or different tubes of the same type giving different results, and no preponderance of results one way or the other. Figure 5 shows a graphic comparison of the results of this test for two particular pairs of output tubes.

An interesting, and rather unexpected, finding was that the capacitor made a

greater relative change in distortion, the closer the system was to balance, with the greatest differences in the two conditions taking place when the currents were adjusted to produce a minimum of third harmonic. This is shown clearly in Fig. 5. The condition for minimum third harmonic was also found to occur very close to that for minimum second harmonic, so close in fact that the two were practically coincident.

For example, when the currents were adjusted for minimum unbalance or minimum third harmonic, addition of the capacitor produced changes of the order of two or four to one. When the currents were greatly out of balance, however, the addition of the capacitor caused changes of the order of only 10 per cent or less, although the distortion terms were much larger, of course. It was also found that the condition for minimum

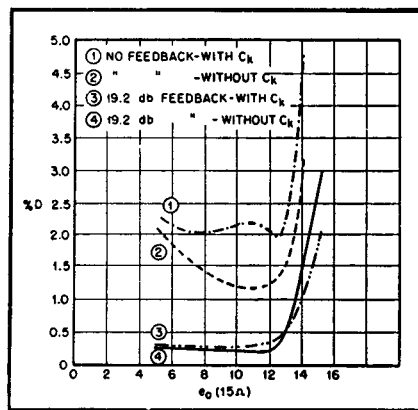

Fig. 3. Harmonic distortion curves on amplifier of Fig. 2. with and without bypass capacitor.

unbalanced current was generally *not* the condition for minimum harmonic distortion. This is not surprising, since the fact that the two tubes are in static balance (d.c. conditions) does not mean that they are also balanced dynamically (a.c. conditions). The purpose of the balancing arrangement in the "Williamson" amplifier is primarily to minimize the unbalanced d.c. current in the output transformer primary, and thereby increase the low-frequency response, while simultaneously reducing core saturation.

Intermodulation Distortion

The next step was to measure the intermodulation distortion of the amplifier, and since the method of measurement was not that most widely used, a brief discussion of the technique will be of interest.

Intermodulation distortion occurs when two or more frequencies interact so as to produce frequency components which are proportional to the product of the input frequencies. One result of such a relationship is the production of frequencies

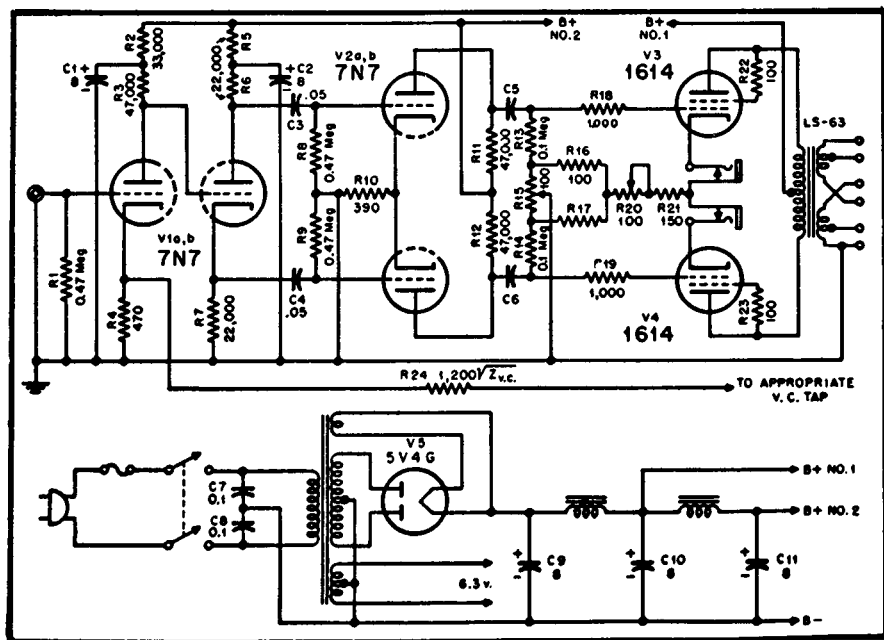

Fig. 2. Complete schematic of first amplifier used in these measurements.

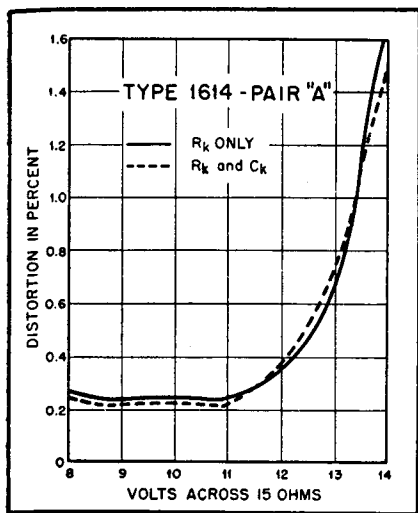

Fig. 4. Same measurements as Fig. 3 with different pair of tubes in the amplifier. These curves are plotted a different scale.

equal to the sum and difference of the two input frequencies, or of one input and harmonics of the other, etc. This action is the basis of our common system of amplitude modulation, where the production of such sidebands is a necessary feature of the process. In the commonly used (and most familiar) method of intermodulation tests, a high-frequency tone (the carrier) is modulated by a low-frequency tone, and the resulting sidebands detected and measured by a suitable circuit.

Although this method is an excellent indication of nonlinearity which generally correlates closely with listening tests, it was found that another method gave results which sometimes seemed to correlate even more closely. This second method of intermodulation distortion measurement also utilizes the fact that difference frequencies are produced. In this method, generally called the CCIF method, two high-frequency tones of equal amplitude and separated in frequency by a fixed amount are applied to the device under test. The output is measured by a wave analyzer tuned to one of the distortion frequencies such as $f_2 - f_1$, $2f_2 - f_1$, or $2f_1 - f_2$, and the distortion voltage is expressed as a percentage of the sum of the two input voltages. Figure 6 shows the two types of intermodulation in graphic form. One noticeable feature of the CCIF type is the location of the difference-frequency component $f_2 - f_1$. Since this component is so far removed from the two input frequencies, there is less tendency for the signal to mask the distortion as there might be in the SMPTE method, or in the CCIF method for the $2f_1 - f_2$ and $2f_2 - f_1$ terms. This difference tone is particularly objectionable when it falls in the region of maximum sensitivity of the ear (400 to 5000 cps), and is noticeable in amounts as small as a fraction of one per cent. It

must be pointed out, however, that due to the difference in method of expressing percentages in the two methods, equivalent percentages are not indicative of equivalent degrees of nonlinearity. The SMPTE values appear relatively high while the CCIF values appear relatively low for the same nonlinearity.²

In using the CCIF method of measurement two procedures are commonly used. One is to select two fixed input frequencies and measure the distortion as the power output is varied. The other is to select a fixed power output level and to vary the two input frequencies simultaneously, maintaining a constant difference frequency. The first is rather readily accomplished, whereas the second requires either a special oscillator such as the General Radio 1303-A, or two oscillators calibrated with sufficient ac-

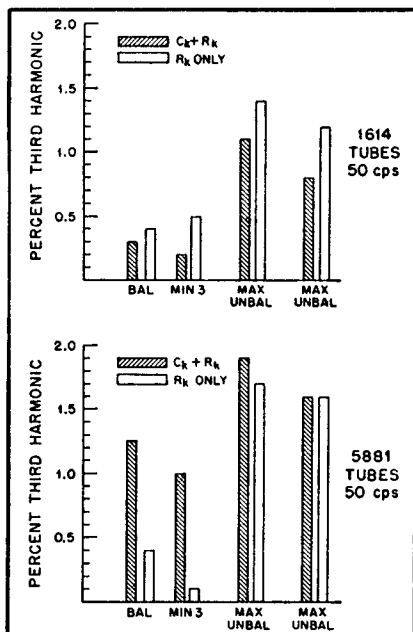

Fig. 5. Comparative distortions with different types of tubes in the output stage show different results.

curacy to enable the difference to be readily distinguished from the dial settings. The stock oscillator in the UTC laboratories is a decade-type oscillator with an accuracy of four places, and consequently is ideally suited to any such application.

Two such oscillators are used with the simple mixer-potentiometer circuit shown in Fig. 7 to provide control of frequency and output of either oscillator and the over-all voltage output. The isolating resistor networks prevent any interac-

² A discussion of the two methods of intermodulation distortion measurement will be found in the General Radio Company Technical Publication B-3, *The Measurement of Non-linear Distortion*, by Arnold Peterson.

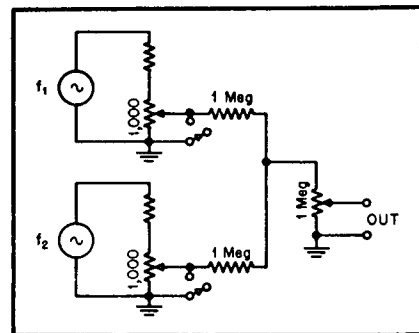

Fig. 7. Method of connecting two audio oscillators to provide CCIF type of IM signal without introducing intermodulation in the mixing circuit.

tion, and consequent intermodulation, between the two oscillators.

The CCIF intermodulation tests were performed using both methods mentioned above. When distortion was measured as a function of power level, the following relations were taken into consideration:

Since two frequencies are involved, a complex (nonsinusoidal) wave is produced, and the indication of an ordinary vacuum tube voltmeter is, therefore, not valid in determining the power level by the customary formula $P = E^2/R$. Furthermore, since one wave rides the other, the peak value of the two waves may reach a value equal to the algebraic sum of the individual waves, with the result that overload can occur for two frequencies when each is only one-half the amplitude required for overload by a single frequency. (See Fig. 8) Since each wave is only one-half the maximum amplitude, it can produce only one-quarter the power of a single maximum-amplitude wave. The power available from two such waves without any possibility of overload is, therefore, only one-half the power available from a single-frequency wave. The curves for the CCIF intermodulation tests are calibrated in terms of volts as read on an audio-frequency

(Continued on following page)

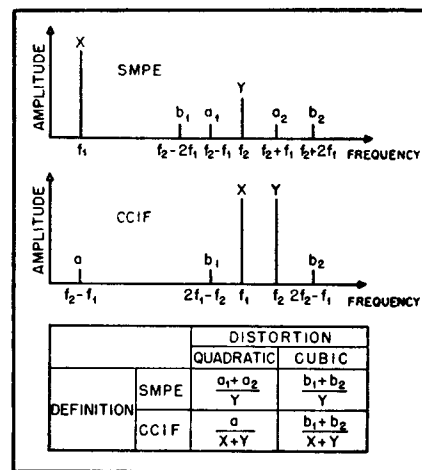

Fig. 6. Comparison of frequencies present in two different types of intermodulation measurements.

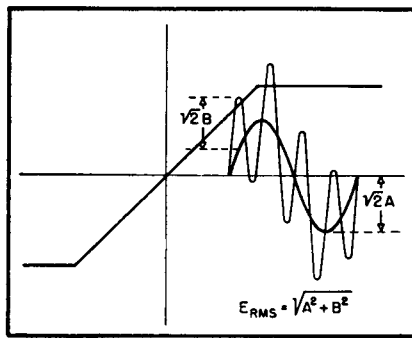

Fig. 8. Graphic representation of possible maximum voltage resulting from mixing two signals of slightly different frequency and of the same amplitude, as in the CCIF method.

vacuum-tube voltmeter. In accordance with the above, maximum power level is equivalent to an output voltage reading of about 9.3 volts on these curves.

The curves of Fig. 9 were obtained by maintaining the indicated input frequencies constant, varying the input voltage up to overload and above, and measuring the first-order difference frequency. The tubes used were 1614's and the difference frequency was 400 cps. Notice that although the difference in distortion is slight, it is almost always lower when the cathode resistor is bypassed. The same results were obtained with 5881's and KT-66's.

The curves of Fig. 10 were obtained by keeping the input voltages constant and varying the input frequencies. This was done for three difference-frequencies, providing a considerable amount of range overlap as shown. The tubes used were KT-66's. Again it is seen that the capacitor effects a slight but definite improvement. (Note that each difference frequency has separate distortion ordinates in Fig. 10).

As a final check the amplifier square-wave response was observed for different amounts of current unbalance. With unbalanced currents up to 10 ma in either direction there was no discernible difference in the output wave shape as the capacitor was added or removed at fre-

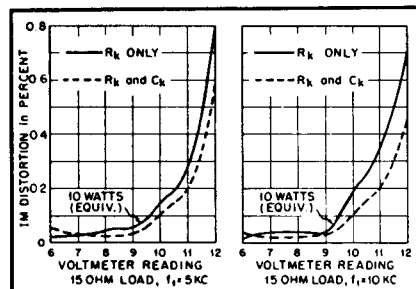

Fig. 9. Effect of capacitor on CCIF intermodulation measurements at two different areas of the frequency spectrum.

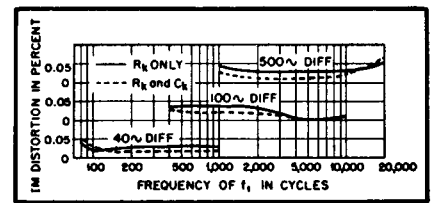

Fig. 10. Effect of capacitor on CCIF intermodulation measurements when difference frequency is varied. (The three pairs of curves are plotted to different base lines.)

quencies from 20 to 20,000 cps. At low frequencies there was a noticeable rounding of the trailing edges as the unbalance exceeded 10 ma. (See Fig. 11) These results were obtained with any of the three types of output tubes.

From the foregoing experiments at least one curious result stands out: In a Class A amplifier the use of a bypass capacitor across the output cathode generally reduces the intermodulation distortion, although it may either decrease or increase the harmonic distortion.

The decision as to whether or not to use such a capacitor depends mainly on the magnitude of the distortion. If it is very small, then it may be safely left off, with no possible audible difference. If it is only moderately low, then the use of a bypass capacitor is advisable.

All of the foregoing applies to a Class A amplifier only. In the case of a Class AB amplifier the bypass capacitor is absolutely necessary if the amplifier is to perform within the modern limits of high fidelity performance.

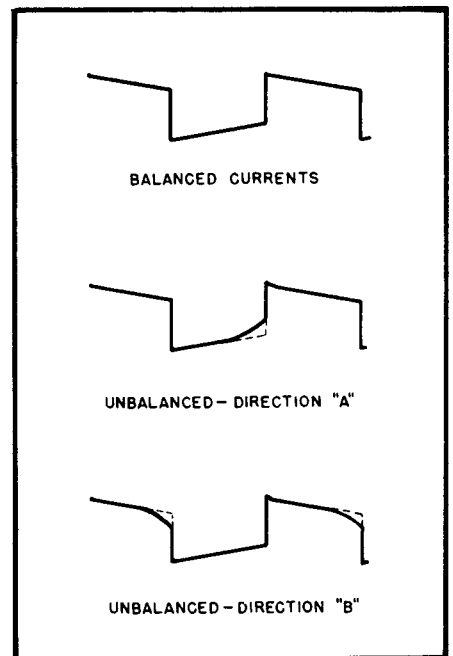

Fig. 11. Effect of current unbalance on square waves. Note that only the low frequency is affected, as indicated by rounding of trailing edge of wave.

CATHODE CAPACITOR

(Continued from preceding page)