

RCA 6CW4 and 2CW4 Nuvistor Triodes as RF Amplifiers in VHF Television Tuners

This Note describes the high-frequency performance of the 6CW4 and 2CW4 nuvistor triodes and their application as rf-amplifier tubes in vhf television tuners. The performance of these tubes is evaluated in an experimental neutralized grid-drive amplifier circuit, an experimental turret tuner, and a production-type switch tuner. Optimum noise-factor data and practical circuit considerations are also presented.

Design Features of the 6CW4 and 2CW4

The 6CW4 and 2CW4 are high-mu, high-transconductance triodes of the nuvistor design, featuring extremely small size and light weight. The cylindrical active elements of the tubes are mounted coaxially on ceramic base wafers. Each element is supported by a tripod arrangement of leads which extend through the ceramic base wafer. One lead of each set is used as the external connector, as shown in the bottom view of Fig.1.

Fig.1 - Bottom view of pin arrangement for the 6CW4 and 2CW4.

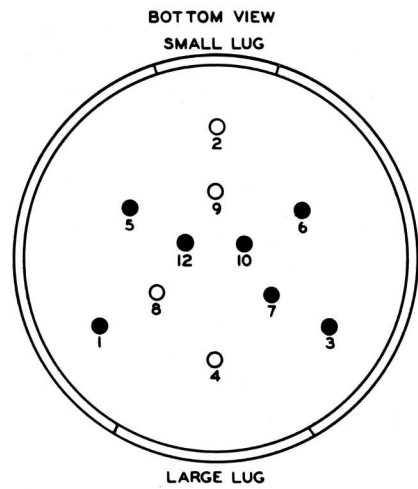

- PIN 1: PLATE
- PIN 2: SEE NOTE
- PIN 3: PLATE
- PIN 4: SEE NOTE
- PIN 5: GRID
- PIN 6: GRID
- PIN 7: CATHODE
- PIN 8: SEE NOTE
- PIN 9: SEE NOTE
- PIN 10: HEATER
- PIN 11: OMITTED
- PIN 12: HEATER

NOTE: INTERNAL CONNECTION. DO NOT USE. PIN IS CUT OFF CLOSE TO CERAMIC WAFER.

Sections of the shell which extend beyond the base wafer serve as indexing lugs for socket insertion. These indexing lugs also provide protection for the tube leads and ground the metal shell through the socket, making the use of a tube shield unnecessary.



Several important advantages are inherent in the unique nuvistor design used in these tubes. For example, high transconductance is obtained with a high transconductance-to-plate-current ratio, as shown by the transfer characteristics in Fig.2. These characteristics are achieved with a considerable reduction of both plate-input and heater-input power.

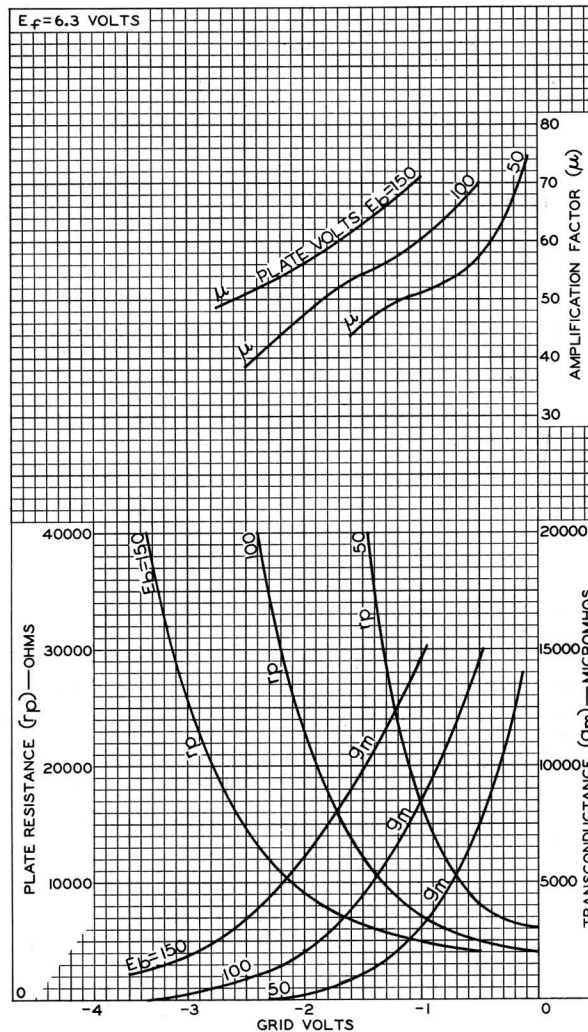

92CM-10520

Fig.2 - Average characteristics for the 6CW4.

Interelectrode capacitances are comparable to those of conventional miniature triodes. In addition, accurate element spacing in the tubes during assembly permits a high degree of uniformity of characteristics from tube to tube, especially with respect to interelectrode capacitances. As a result, tubes can be replaced with a minimum of circuit adjustment.

The small size and short lead lengths of the tubes make them particularly suitable for rf-amplifier applications in vhf television tuners. The high transconductance-to-plate-current ratio contributes to low tube noise factor. In addition, short-circuit input-impedance measurements indicate that these tubes have higher input resistance than other tubes having equivalent input capacitance and transconductance. These measurements approximate the input resistance of a completely neutralized triode



in grid-drive operation. As shown by the following equation for power gain at vhf frequencies (impedance-matching losses neglected), increased input resistance results in increased gain.

$$\text{Power Gain} = \frac{\mu^2 R_s R_L}{(r_p + R_L)^2}$$

where μ is the amplification factor,
 R_s is the source resistance (matched to input resistance),
 R_L is the load resistance, and
 r_p is the plate resistance of the tube.

Neutralized Grid-Drive Amplifier

Fig.3 is a circuit diagram of a neutralized grid-drive amplifier employing a 6CW4. In this circuit, input and output networks are matched to a 50-ohm signal generator and load impedance, respectively. A capacitive-bridge network is used for neutralization. The plate circuit, a double-tuned transformer-coupled network tuned to 200 megacycles, has a six-megacycle bandwidth. For determination of optimum noise factor, source admittance was varied by use of the "pi" input-matching network. Fig.4 shows curves of noise factor and gain as functions of source conductance and susceptance for this circuit.

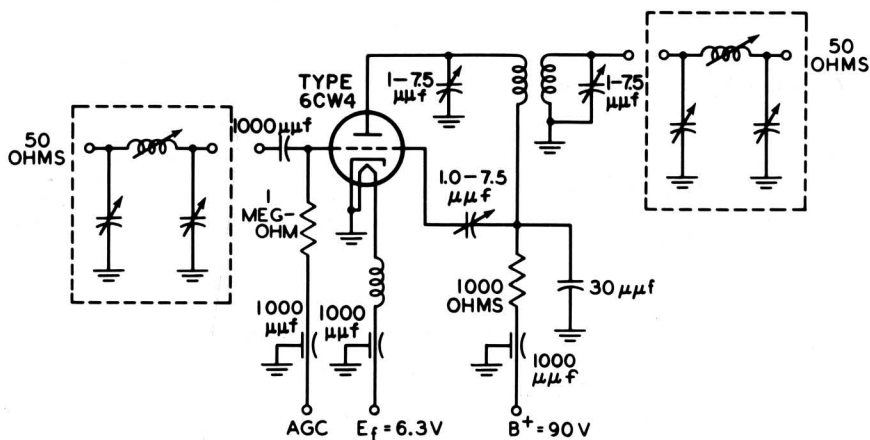

Fig.3 - Circuit diagram of a neutralized grid-drive amplifier employing the 6CW4.

Noise-factor measurements were made by use of a coaxial temperature-limited diode noise generator. The noise power of the circuit, as indicated by a detected output signal, was increased 3 db by the introduction of rf noise signals from the noise generator. The noise generator used was calibrated to indicate noise factor directly when the noise power was doubled.

A substitution method was used for measurement of power gain. In this method, the voltage output of a signal generator was set to some arbitrary reference level. The amplifier was then placed in the circuit, and the signal-generator output was attenuated to reduce the amplified signal to the original reference level. The difference between the dial readings of the signal generator, which was calibrated in db, indicated the gain of the amplifier directly.

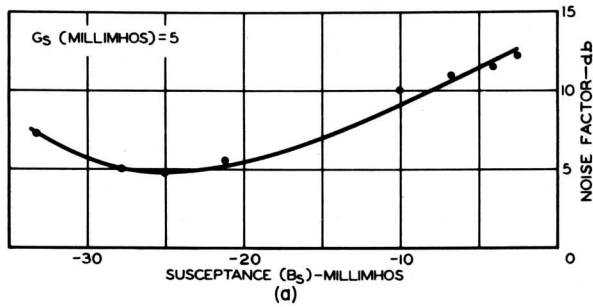

Fig.4(a) - Noise factor as a function of susceptance for the amplifier shown in Fig.3.

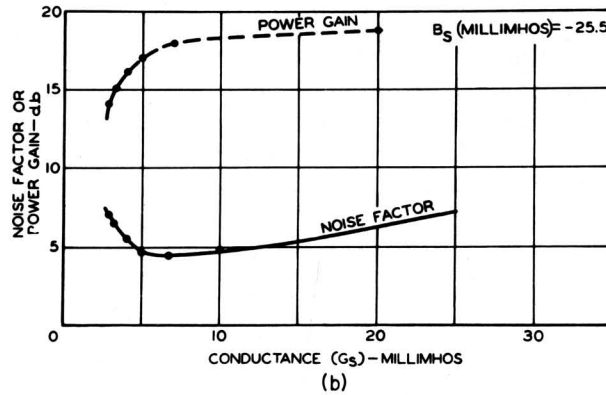

Fig.4(b) - Noise factor and power gain as functions of conductance for the amplifier shown in Fig.3.

Turret Tuner and Switch Tuner

Fig.5 is a circuit diagram of the rf-amplifier section of an experimental turret tuner. In this circuit, a 300-to-70-ohm balanced-to-unbalanced transformer input is used for impedance matching, and a mixer tube serves as the load for the rf section. Conventional tuner

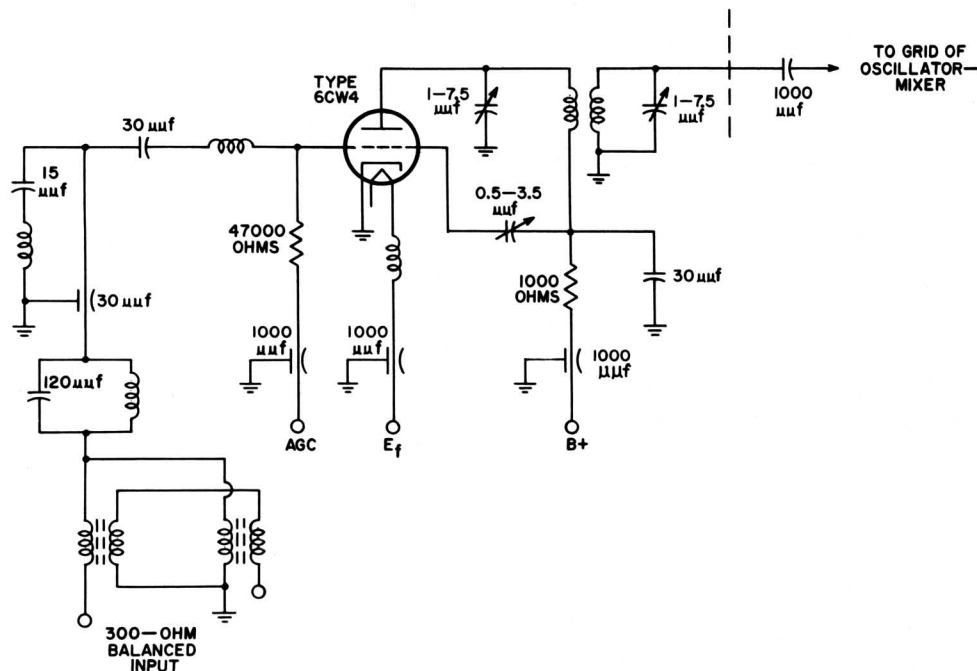

Fig.5 - Circuit diagram of the rf-amplifier section of an experimental turret tuner.



design techniques and components are used throughout. Noise factor and over-all tuner voltage-gain performance are tabulated in Table I.

Channel	Noise Factor (db)	Tuner Voltage Gain (db)
2	3.9	47.9
6	4.0	45.3
7	5.3	45.0
13	5.5	44.0

Table I - Noise-factor and gain performance of an experimental turret tuner employing a 6CW4 at different television-channel frequencies.

Similar data are shown in Table II for a production-type switch tuner using a 6CW4. The circuit for this tuner is almost identical to those shown in Figs. 3 and 5; however, the load on the tuned circuits is increased to improve coupling on the lower-frequency channels.

Channel	Noise Factor (db)	Tuner Voltage Gain (db)
2	5.1	45.0
6	5.0	43.5
7	4.7	44.5
13	5.5	45.0

Table II - Noise-factor and gain performance of a production-type switch tuner employing a 6CW4 at different television-channel frequencies.

A 50-ohm signal generator equipped with a balun to match to the tuner input was used for gain measurements of the turret tuner and switch tuner. Both tuner circuits incorporated a dummy if stage consisting of an if-amplifier tube with a 10,000-ohm grid resistor. Again, the substitution method outlined previously was used to measure gain. Table III compares the average performance of the 6CW4 at channel 13 with that of conventional miniature types in the same circuit.

Tube Type	Noise Factor (db)	Tuner Voltage Gain (db)
6BN4-A	8.5	38.0
6FH5	7.5	41.0
6ER5	7.5	41.0
6CW4	5.5	45.0

Table III - Noise-factor and gain comparison of the 6CW4 with conventional miniature triodes in a television tuner at channel 13.

General Considerations

The 6CW4 and 2CW4 are designed to operate at relatively low plate voltages for best rf performance. Optimum tuner performance is obtained



with a plate voltage in the order of 70 to 80 volts. Fig.6 shows curves of noise factor and tuner gain as a function of plate power dissipation at various B+ values applied to the tuner. The B+ voltage is dropped slightly across a 1000-ohm resistor. At a given level of plate dissipation, performance improves as the plate voltage is reduced. (The limit of plate-voltage reduction is determined by the amount of plate current that can be drawn without the application of positive bias voltage.) The optimum plate voltage is determined as a balance between performance and plate dissipation. Maximum signal-to-noise ratio at a given plate voltage is obtained at an applied bias of zero volts.

Under these conditions, the 6CW4 and 2CW4 have a sharp-cutoff characteristic which is unsuitable in systems employing agc. Supply voltages available in television receivers are, however, considerably higher than the operating plate voltage of these tubes. As a result, cutoff can easily be extended by the addition of a plate-voltage dropping resistor. Fig.7 shows curves of gain reduction as a function of grid bias for different values of supply voltage. As indicated, the circuit designer determines the value of plate-voltage dropping resistor or series shunt combination which provides the desired cutoff characteristic.

Use of the 6CW4 or 2CW4 with a series dropping resistor at high supply voltages requires careful choice of tube-element operating values so that maximum ratings are not exceeded. Maximum plate dissipation, for example, does not necessarily occur when the tube is drawing maximum plate current, but can occur at some bias value other than zero. Fig.8(a) shows a circuit configuration using a typical 6CW4. Fig.8(b) shows curves of plate dissipation as a function of bias voltage obtained from the agc circuit. With the indicated circuit and voltage values, maximum plate dissipation (as shown by the solid-line curve) occurs at a bias voltage of slightly less than one volt.

With the values of resistors adjusted to either the upper or lower limits of their 10-percent tolerances to simulate the worst probable conditions of operation and with the high heater and B+ voltages indicated,

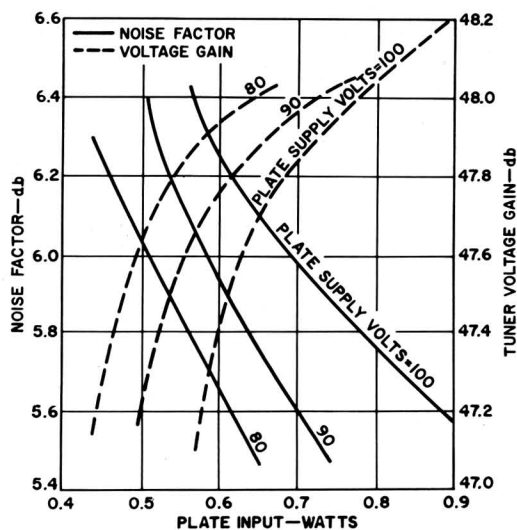

Fig.6 - Voltage gain and noise factor as functions of input power for various B+ voltages applied to the turret tuner.

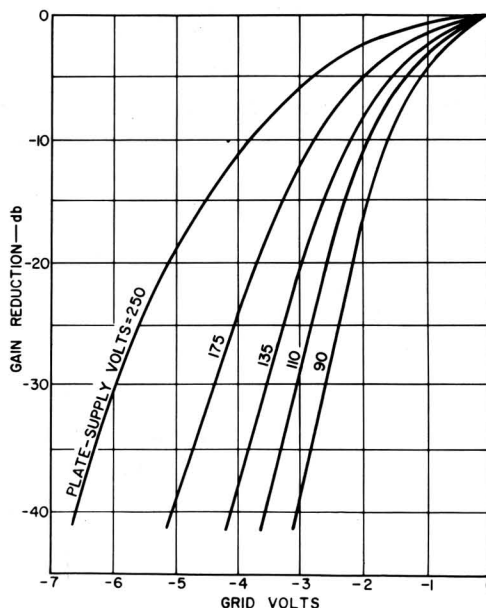
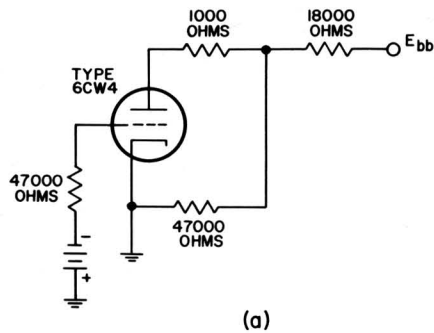
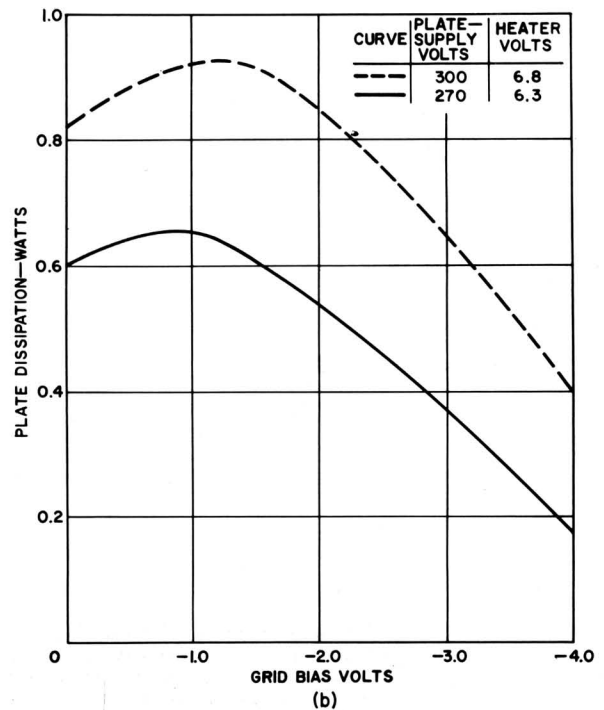

Fig.7 - Gain reduction as a function of grid-bias voltage for different values of supply voltage.



(a)

Fig.8(a) - Typical circuit configuration using the 6CW4 and (b) - curves of plate dissipation as a function of agc bias voltage under normal and worst probable conditions of operation.



the resultant maximum plate dissipation is shown by the dashed curve in Fig.8(b). In this case, maximum plate dissipation occurs at a bias voltage slightly above 1 volt. The equipment designer has the responsibility of choosing values of circuit components which will prevent maximum ratings of the tube from being exceeded under the worst probable operating conditions.

As mentioned previously, optimum performance of the 6CW4 and 2CW4 is obtained when they are operated with an applied bias of about zero volts. Under these conditions, the tube draws current, and is at some negative potential depending on the grid impedance to ground. Because automatic-gain-control systems generally present high impedances to ground, care must be taken to assure that a low grid bias voltage is applied to the tube. A common method is to return the agc terminal to a positive voltage through a large-value resistor to clamp the grid voltage at low signal levels.

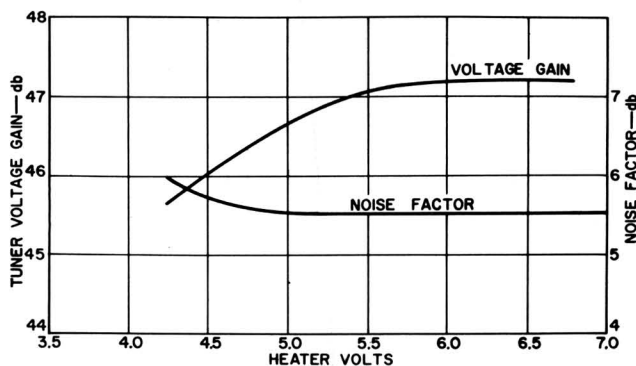

Fig.9 - Voltage gain and noise factor as functions of heater volts for the turret tuner.

Fig.9 shows the variation of tuner noise factor and voltage gain produced by reduction in heater voltage. The curves show that noise factor is only slightly affected at reduced heater voltage, and that gain drops only about 0.5 db with a change in heater voltage from 6.3 to 5.0 volts.

Information furnished by RCA is believed to be accurate and reliable. However, no responsibility is assumed by RCA for its use; nor for any infringements of patents or other rights of third parties which may result from its use. No license is granted by implication or otherwise under any patent or patent rights of RCA.



ERRATA NOTICE

for

Application Note AN-191 "RCA 6CW4 and 2CW4 Nuvistor Triodes as RF Amplifiers in VHF Television Tuners"

The bottom view of pin arrangement for the 6CW4 and 2CW4 nuvistor triodes was incorrectly shown on page 1 of AN-191 issued 2-61. The proper pin arrangement and connections are as shown below:

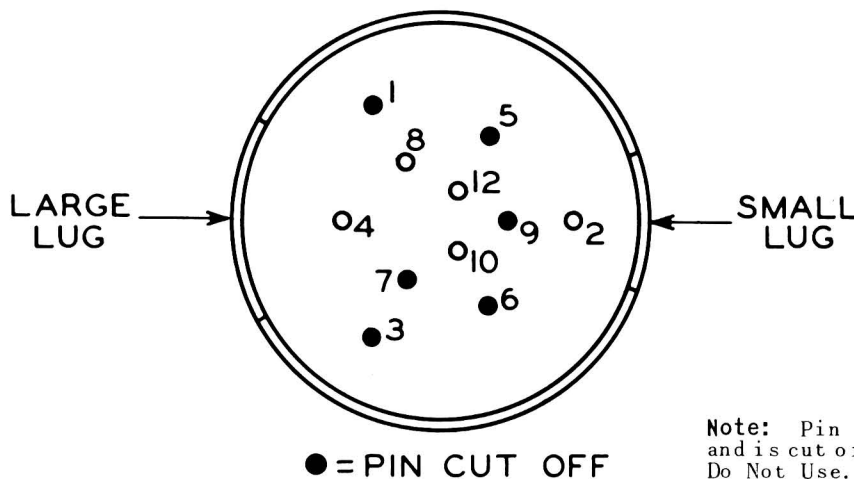

- PIN 1 - SEE NOTE
- PIN 2 - PLATE
- PIN 3 - SEE NOTE
- PIN 4 - GRID
- PIN 5 - SEE NOTE
- PIN 6 - SEE NOTE
- PIN 7 - SEE NOTE
- PIN 8 - CATHODE
- PIN 9 - SEE NOTE
- PIN 10-HEATER
- PIN 11-OMITTED
- PIN 12-HEATER

Note: Pin has internal connection and is cut off close to ceramic wafer. Do Not Use.