

PROCEEDINGS
of the
RADIO CLUB *of* AMERICA



Vol. 2 No. 8

March, 1923

R.C.A. SPECIAL NOTICES

This month's paper by Prof. Hazeltine marks an epoch in receiver construction and is a practical example of the valuable experimental work constantly being done by our Club members. The importance of Prof. Hazeltine's system can hardly be appreciated at this early date but will grow in magnitude as his circuits become better known.



We regret that we are yet unable to announce the results of the election of officers for 1923 as the ballots are still coming in. We hope to have complete returns in the next issue.



BOARD OF EDITORS

Walter S. Lemmon—*Editor*—342 Madison Ave., New York
Ernest V. Amy
Pierre Boucheron
Lester Spangenberg



Tuned Radio-Frequency Amplification with Neutralization of Capacity Coupling



By L. A. Hazeltine

Professor of Electrical Engineering, Stevens Institute of Technology

(A paper presented before the Radio Club of America, March 2, 1923.)

In this paper is described what we consider the greatest contribution yet made to the successful operation of R.F. amplification on 200 meters. In fact, we believe it completely solves the problem. In this paper Prof. Hazeltine shows how tuned R.F. amplification may be used, with all the benefits of resonant circuits, yet with complete elimination of the tendency to oscillate, the bugbear of every experimenter. Regeneration or oscillation may be utilized in the detector, with no effect upon the preceding amplifiers. This is a contribution of particular application to the work of the telegraphing amateur—Editor.

1. Principle of Neutralization of Capacity Coupling—The specific subject of this paper, "tuned radio-frequency amplification," is but one of a number of practical applications of a general principle: that electrostatic or capacity coupling between two circuits behaves like electromagnetic coupling in that it may be reversed in sense and in particular may be reduced to zero. This is accomplished by balancing one capacity against another. To attain the balance condition, it is generally necessary to reverse the phase of a voltage; and this involves the use of a transformer in addition to the capacities.

Any system of circuits coupled through capacities may be resolved into elements

such as indicated in Fig. 1, where the two circuits A and B are coupled through the direct connection at the bottom and through the capacity C_1 . To neutralize this coupling, two closely coupled coils L_1 and L_2 , and a neutralizing capacity C_2 , are arranged as shown, L_1 being connected between one terminal of C_1 and the common connection, and L_2 being connected in series with C_2 between the other terminal of C_1 and the common connection. The terminals of L_1 and L_2 , which are connected together are of unlike polarity.

If we regard circuit A as having the source of alternating current, the alternating potential of its upper terminal (marked "disturbing potential," Fig. 1a)

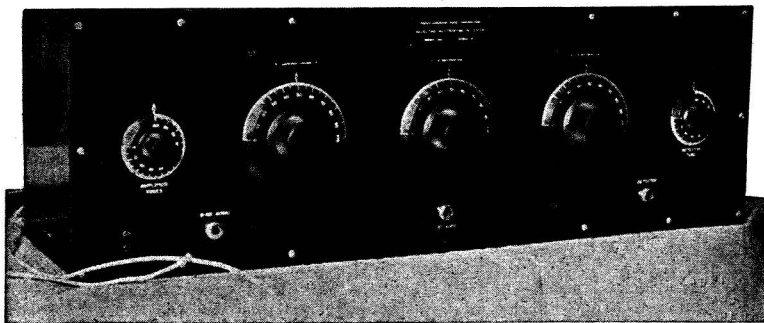

A HAZELTINE NEUTRODYNE RECEIVER

Front view, showing simplicity of controls. The small left-hand knob is the rheostat controlling all the amplifier filaments, the right-hand the detector filament. The first large dial controls antenna tuning, the center dial the first radio transformer, and the next dial the second radio transformer. (Photo courtesy Freed-Eisemann Corpn.)

would send a current through C_1 to circuit B, which current in flowing through the impedance of B would set up a voltage between the terminals. Thus, in the absence of neutralization, power would be transferred from A to B. Now if the neutraliz-

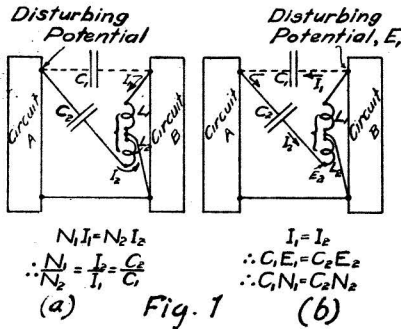

ing circuit L_1, L_2, C_2 be introduced and be so adjusted that the current I_1 through L_1 magnetically balances the current I_2 through L_2 , no voltage will exist across either of these coils nor across B, which is in parallel with L_1 . The condition of magnetic balance is

$$N_1 I_1 = N_2 I_2 \text{ ampere-turns,} \quad (1)$$

where the N 's are the respective numbers of turns of the coils. If no voltage exists across B, no current will flow through it; so all of the current through C_1 will be the current I_1 of coil L_1 . Also the current through C_2 is the current I_2 of coil L_2 . Since no voltage exists across the coils, the two condensers have equal voltages and their currents are therefore in the ratio of their capacities:

$$\frac{I_2}{I_1} = \frac{C_2}{C_1} \quad (2)$$

Combining these relations,

$$\frac{N_1}{N_2} = \frac{C_2}{C_1} \quad (3)$$

which is therefore the condition for neutralization of capacity coupling.

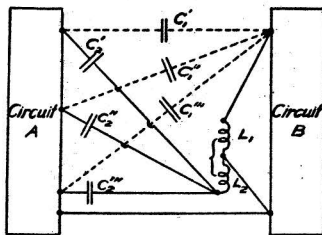

Fig. 2

The general reciprocal relation of electric circuits proves that if a source in A

does not affect B (as described above), then a source in B will not affect A. However, it seems worth while to examine the details of this case, which is illustrated in Fig. 1b. The "disturbing potential" at the upper terminal of B will send a current I_1 through C_1 . If adjustments are so made that the current I_2 through C_2 is equal to I_1 , then no current flows into A and no voltage is set up in A. Since the current through a capacity is proportional to the capacity and to the voltage, we then have

$$C_1 E_1 = C_2 E_2, \quad (4)$$

where E_1 and E_2 are the voltages across C_1 and C_2 respectively. There being no voltage across A, the junction of the L 's is at the same potential as the junction of the C 's; so E_1 and E_2 are also the voltages of coils L_1 and L_2 and are proportional to the respective numbers of turns:

$$\frac{E_1}{E_2} = \frac{N_1}{N_2} \quad (5)$$

Hence, combining, we must have

$$\frac{N_1}{N_2} = \frac{C_2}{C_1} \quad (5')$$

as before.

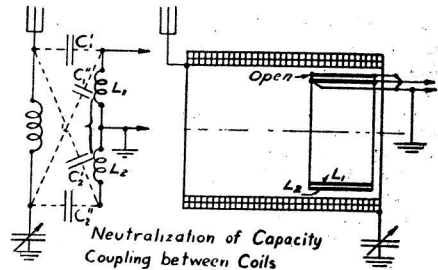

Fig. 3

If C_2 is smaller than given by (3), C_1 will be under-neutralized, and the circuits will be so coupled in the same sense as if there were no neutralization. If C_2 is larger than given by (3), C_1 will be over-neutralized, and the circuits will be coupled in the opposite sense; by which we mean that the phases of all currents and voltages produced in one circuit by a source in this other will be opposite to what they would have been without neutralization. The adjustment of C_1 is thus analogous to the adjustment of magnetic coupling by the rotation of a coil through the position of zero mutual inductance.

Sometimes it happens that two circuits will be coupled by a number of capacities extending from a single point of one circuit to various points of the other, as indicated by C_1', C_1'' and C_1''' , Fig. 2. In this case a single transformer L_1, L_2 suffices, but each coupling capacity must be

separately balanced by a neutralizing capacity, as C_2' , C_2'' , C_2''' . The relations for a balance are, as previously,

$$\frac{N_1}{N_2} = \frac{C_2'}{C_1'} = \frac{C_2''}{C_1''} = \frac{C_2'''}{C_1'''} \quad (7)$$

2. **Miscellaneous Application of Capacity Coupling Neutralization.**—Historically the first application of the principle described above was in eliminating capacity coupling between the primary and secondary circuits of a radio receiver (SE-1420) designed by the author for the U. S. Navy and developed in the Washington Navy Yard in 1918. This receiver was to have a wide range in wavelength (about 250 to 7500 M.) and emphasis was laid on the necessity of preventing interference from short wavelengths when receiving signals

to its exposure to the primary coil; and thus the idea of employing the current to more effectively eliminate capacity coupling led at once to the method now being discussed.

The arrangement adopted in the SE-1420 (and in fact the only arrangement tried) is illustrated in Fig. 3. The large coil is the primary tuning coil; L_1 is the coupling coil; and L_2 , wound outside of L_1 , is the neutralizing coil. The inherent capacities from the high-potential end of L_1 to various parts of the primary coil are represented by C_1' and C_1'' ; the corresponding neutralizing capacities are C_2' and C_2'' . These various capacities have a constant ratio, on account of the similar exposure of L_1 and L_2 to the primary coil. Hence it is necessary only to give L_2 the proper number of turns relative to L_1 in order to satisfy (7).

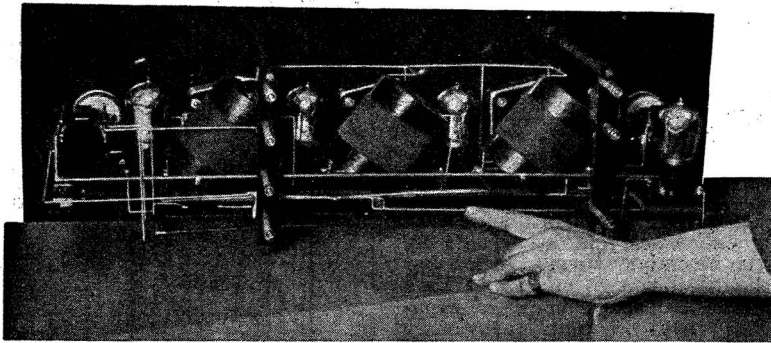

REAR VIEW OF A HAZELTINE NEUTRODYNE

Each of the coils shown is in reality a tightly-coupled two-winding transformer, a litz primary being wound on a tube just small enough to slip inside the winding shown, which is the secondary. The turns-ratio is 1:4. Note the peculiar angle at which the coils are set to avoid any electromagnetic coupling.

Two of these transformers are used as R.F. transformers, with a 11-plate tuning condenser across the secondary. The coupling is so tight that the effect is the same as tuning the primary circuit. The third transformer, with a similar tuning condenser, is used between the antenna and the first R.F. tube, giving single-control tuning, with the antenna acting almost purely as a collector.

The neutralizing capacity, indicated by the operator's hand, consists of a small piece of brass tubing sliding over the ends of two insulated wires. When the proper adjustment is attained, as described in the accompanying text, the capacity is fixed by sealing the tube in place. (Photo courtesy Freed-Eisemann Corpn.)

of long wavelength, such interference frequently taking place through capacity coupling. The first steps were the more obvious ones of arranging the circuits, so that exposed parts were at or near ground potential and of enclosing the primary and secondary apparatus in separate metal compartments. However, the primary tuning coil and the secondary coupling coil had to be electrostatically exposed to one another in order to obtain the necessary magnetic coupling.

The first thought in eliminating this residual capacity coupling was to wrap a grounded wire around the coupling coil. In considering the most practical way of arranging such a wire screen, the author realized that it would carry a current due

Since L_2 is outside of L_1 it also has a direct screening action, making C_1' , C_1'' , smaller than they would otherwise be, and smaller than C_2' , C_2'' . Hence L_2 requires fewer turns than L_1 . The proper number of turns N_2 was determined experimentally by putting the coils at right angles (so as to eliminate magnetic coupling) and adjusting N_2 until no signal was transmitted.

An application of the method under discussion, which is similar in several respects to that of the receiver just described, is to an alternating current Wheatstone bridge, as illustrated in Fig. 4. Here it is desirable to ground both the supply circuit and the detector circuit. This requires an insulating transformer in the detecting circuit and the absence of capacity coupling

between windings. The theory of the arrangement shown is the same as that just given; so separate discussion is unnecessary.

3. Capacity Coupling Neutralization in Amplifiers.—While studying the theoretical limitations of amplifier circuits in 1918, the author realized that a most serious limi-

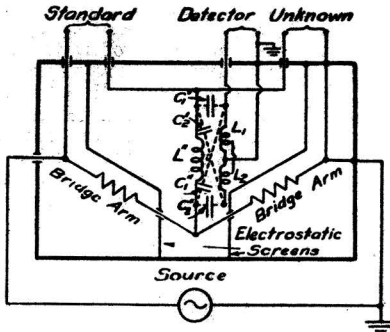
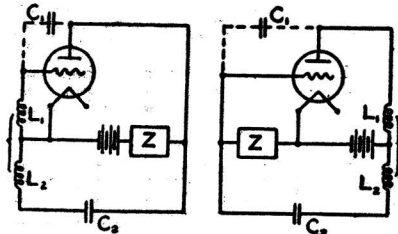

Fig. 4

tation was the tendency to oscillate by reason of regeneration through the coupling capacity between the grid and the plate. The higher the amplification attempted, as by reducing capacities and losses and by increasing the secondary turns, the greater would be the regenerative effect. It then occurred to him that the principle of capacity coupling neutralization previously worked out for the SE-1420 receiver would be applicable.

The two converse modes of applying the neutralization principle to triode vacuum tubes are illustrated in Fig. 5. In both



Neutralization of Capacity Coupling
in Triode Vacuum Tubes

(a) Fig. 5 (b)

parts of this figure Z represents any impedance, as a transformer winding; the coils L_1 , L_2 are closely coupled as before and have a ratio of turns N_1/N_2 equal to C_2/C_1 , the ratio of the neutralizing capacity C_2 to the inherent coupling capacity C_1 , as in equation (3).

In practically applying the arrangements of Fig. 5 to amplifiers, the coil L_2 may of course be used wholly for neutralization purposes; but it is convenient to use it also as one winding of an amplifying transformer, thus making a third coil unnecessary. Fig. 6 and 7 show how this may be accomplished. As the ratio of transformation will usually be fixed by other considerations, C_2 will be used for the balancing adjustment. These figures also show how all coupling capacities except those inside the tubes may be eliminated by enclosing the circuits in metal compartments and certain of the leads in metal tubes.

The name *neutrodyne* has been given by the author to the method of neutralizing capacity coupling in triode amplifiers. It suggests the neutralization of a "force," the tendency of the triode to oscillate, and contrasts with "heterodyne," which employs oscillation.

Three classes of amplifier are of importance: audio-frequency, untuned radio-frequency and tuned radio-frequency. All are in a sense tuned, but the two former are designed to cover a broad band of fre-

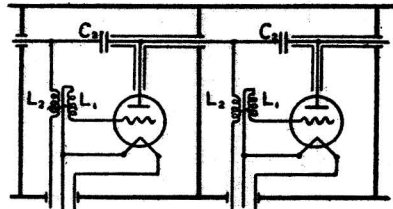

Multistage Amplifier with
Capacity Coupling Neutralization

Fig. 6

quencies, while the last is sharply tuned for the purpose of giving high selectivity. Sharp tuning of the plate circuit, or of a circuit closely coupled to the plate circuit, is especially conducive to regeneration, being in fact one of the most common methods for securing regeneration in detector circuits. Neutralization of capacity coupling, while useful in all classes of amplifier, is therefore particularly necessary in tuned radio-frequency amplifiers. The previous lack of such a method of preventing undesirable regeneration has prevented radio-frequency amplifiers from going into general use.

Fig. 8 shows a tuned two-stage radio-frequency amplifier and detector with capacity coupling neutralization of the form of Fig. 5b. The neutralizing capacities are in part inherent, existing between the coils and condensers of adjacent stages, and in part added by condensers. These condensers are of very small capacity and are conveniently made in the form of an in-

ulated wire inside a metal tube. The secondary coils of the transformers are preferably wound outside the primaries and so screen away some of the coupling capacity otherwise existing between the primary coil of one stage and the secondary circuit of the preceding stage. This screening effect is just like that of Fig. 3 and is advantageous, as it reduces the capacity to be neutralized. The coils of different transformers are, of course, arranged to have no magnetic coupling.

The adjustment of each neutralizing capacity is made experimentally by tuning in some strong signal and then turning out the filament of the tube whose capacity is to be adjusted, but leaving the tube in its socket. If the neutralizing capacity is not correct, the circuits on each side of the tube will have capacity coupling, which will transmit the signal. The neutralizing capacity is then adjusted until the signal disappears. This method of adjustment clearly illustrates that the neutrodyne circuit operates to eliminate capacity coupling and is not a method for counteracting the effects of regeneration; for the adjustment is made with the filament cold and therefore under conditions when the tube can have no regenerative action. This ingenious method of adjustment was devised by Mr. Harold A. Wheeler, who has done independent work along the lines of the neutrodyne circuit.

The neutrodyne principle is not inconsistent with regeneration; for it may be applied both to regenerative and to non-regenerative receivers. When applied to

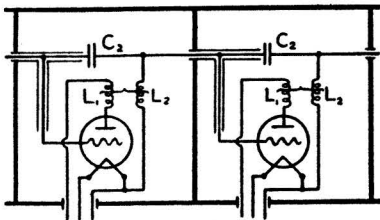

Multistage Amplifier with
Capacity Coupling Neutralization

Fig. 7

non-regenerative receivers it eliminates any inherent means whereby regeneration might occur, and so contrasts with devices such as "stabilizers" which do not remove regeneration but merely weaken its effect. When applied to regenerative receivers, the neutrodyne principle serves to eliminate undesirable regeneration, such as might interfere with proper tuning and might cause radiation from receiving antenna. Fig. 8 shows a suitable way to add regeneration to a neutrodyne circuit—by applying it to the detector tube, as by tuning the plate

circuit. Such a receiver may be operated oscillating; the frequency of oscillation is then determined by the tuning of the detector tube circuits, while the other tuning adjustments serve only to vary the signal strength, as with non-regenerative receivers. This is well illustrated in the practical operation of the receiver by the fact that adjustment of the tuning of an amplifier tube may be made over the entire

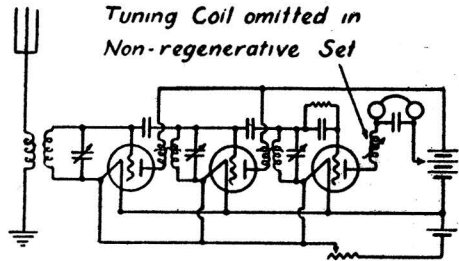

Regenerative Neutrodyne Receiver

Fig. 8

scale without causing a beat note to disappear, the intensity varying rather than the pitch.

Whether regeneration is or is not desirable in a neutrodyne receiver is not, in the author's opinion, a question with a single answer. It is well known that in radio telephone reception by unskilled operators regeneration has frequently been found objectionable on account of distortion, beat notes and squeals. Regeneration also introduces another adjustment and makes tuning more difficult. Such objections apply to neutrodyne receivers as well as to other types; while in addition regeneration adds relatively little to the signal strength in a properly designed neutrodyne set at wavelengths from 360 meters up. On the other hand, at 200 meters the increase in signal strength due to regeneration is decided and is well worth while to amateurs who are accustomed to careful operation of receivers. Of course, regeneration for heterodyne purposes is essential to continuous-wave telegraph reception, to which the neutrodyne receiver is well suited.

Audio-frequency amplification may be combined with the neutrodyne radio-frequency amplification in the usual ways. Fig. 9 shows two stages of radio-frequency, detector and one stage of audio-frequency. Fig. 10 shows a reflex arrangement in which the first radio-frequency tube is used also as an audio-frequency amplifier. In either of these forms, more stages of audio-frequency amplification may be added and jacks may be readily arranged so as to cut out some or all of the audio-frequency am-

plification, without upsetting the neutrodyne balance.

4. Practical Results obtained with Neutrodyne Receivers—While study of the neutrodyne receiver is by no means concluded, it may be of interest to record some of the results and conclusions so far obtained. The work described was conducted in the Electrical Engineering Laboratory of Stevens Institute of Technology, Hoboken, N. J. Using a 60-foot antenna, a three tube non-regenerative receiver consisting of two stages of radio-frequency amplification and a detector has regularly brought in on head telephones broadcasting from Fort Worth (Texas), Kansas City, St. Louis and Minneapolis. A four-tube reflex set, as in Fig. 10, brings in Atlanta on a loud speaker when no antenna is used.

Broadcasting from Los Angeles has been received in Newark, N. J., on a four-tube non-regenerative neutrodyne set. The author lent his first model to two of his amateur friends, and each brought back the same story—that they had heard every district in the United States on the same night. This was with regeneration by means of tuning the plate circuit of the detector tube, as in Fig. 8.

As an example of selectivity, the author has heard Fort Worth, Texas, and has been able to distinguish music from speech, during interference from WEAJ, the American Telephone and Telegraph Company's station in New York City, directly across the Hudson River and about a mile

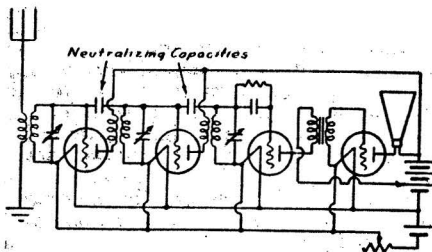

*Non-Regenerative Neutrodyne Receiver with
One Stage Audio-Frequency Amplifier*

Fig. 9

from the Laboratory. The difference in wavelength was about 15 meters in 400. This also was with two stages of radio-frequency amplification.

The adjustment of the neutralizing capacities (which is made once for all when the receiver is first tested) is independent of the frequency, within ordinary practical limitations. Tubes of the same type may be substituted without upsetting the bal-

ance, and even tubes of different types, provided the grid-plate capacity does not differ greatly.

A radio-frequency voltage amplification per stage of about 10 is readily attained for the usual broadcasting wave-lengths. This is equivalent to an audio-frequency amplification equal to the square of this value, 100, or a power amplification of 10,000, per stage. Thus the two tuned radio-frequency stages give a power amplification at the telephone receiver of the order of one hundred million.

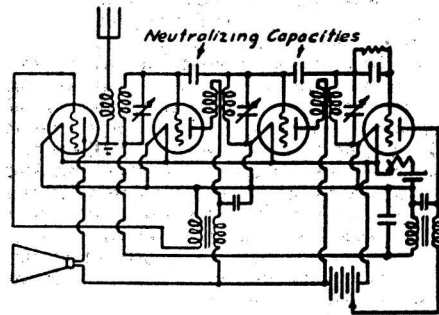

Reflex Neutrodyne Receiver

Fig. 10

In non-regenerative neutrodyne receivers, all adjustments are independent of one another, thus greatly facilitating operation. The tuning of each stage is sharp but not extremely critical; these adjustments are only those demanded by the degree of selectivity attained. The choice of battery voltage differs in no way from that for ordinary forms of receivers. The absence of regeneration makes the received music or speech conspicuously clear and free from distortion, with no local noises.

Both regenerative and non-regenerative neutrodyne receivers obviate the serious objection commonly raised against regenerative receivers, interference with nearby receiving sets due to oscillations set up in the antenna. No oscillations are present in the non-regenerative form; while in the regenerative form they exist only in the detector circuit, being confined thereto by the absence of coupling between stages except the unilateral mutually conductive coupling of the tubes.

Summing up, the neutrodyne circuit in effect is a simplification of previous circuits, not an elaboration. It eliminates a previously existing disturbing feature and so gives pure relay amplification.